

TOPPER-II

INSTALLATION AND SERVICE MANUAL

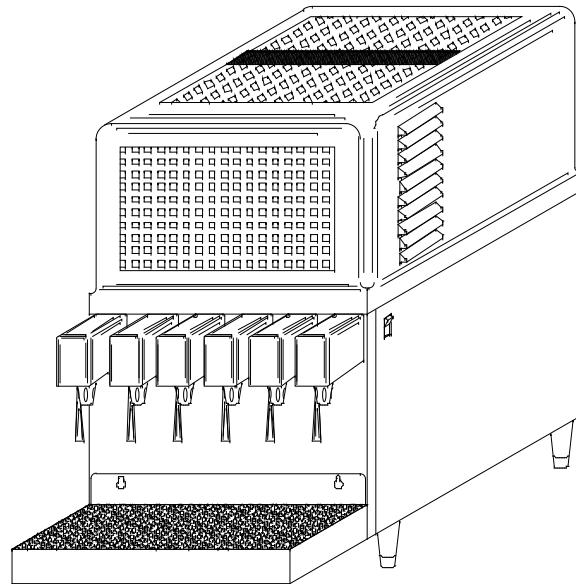

INTERNATIONAL CARBONIC INC.
16630 KOALA RD
ADELANTO, CALIFORNIA

IMPORTANT: This manual is a guide for installing, operating, servicing and maintaining this equipment. Refer to Table of Contents for page location of detailed information to answer questions that arise during installation, operating, service and maintenance, or installation of this equipment.

TABLE OF CONTENTS

	PAGE
PREFACE	1
CHAPTER I <u>GENERAL DESCRIPTION</u>	1-1
SYSTEM DESCRIPTION	1-1
THEORY OF OPERATION	1-12
CHAPTER II <u>INSTALLATION</u>	2-1
UNPACKING AND INSPECTION	2-1
SELECTING LOCATION	2-1
LOCATION RECOMMENDATIONS FOR TOPPER-II	2-2
INSTALLATION	2-2
INSTALL COOLING UNIT	2-2
INSTALL HIGH-PRESSURE CO2 REGULATOR, CO2 CYLINDER AND LINES	2-3
INSTALL LOW-PRESSURE REGULATOR AND LINES	2-3
INSTALL WATER FILTER ASSEMBLY, (OPTIONAL)	2-4
INSTALL WATER PRESSURE REGULATOR, (OPTIONAL)	2-4
INSTALL WATER HOLDING TANK, (OPTIONAL)	2-4
INSTALL DRAIN LINE	2-5
INSTALL B.I.B. OR SYRUP TANKS AND ACCESSORIES	2-5
CONNECTING WATER INLET	2-5
ELECTRICAL REQUIREMENTS	2-5
CHAPTER III, <u>PREPARATION</u>	3-1
PREPARING SYSTEM FOR OPERATION	3-1
PREPARING AND STARTING REFRIGERATION UNIT	3-1
PURGE DISPENSING VALVES	3-1
ACTIVATE HIGH-PRESSURE CO2 SYSTEM	3-1
ACTIVATE LOW-PRESSURE CO2 GAS AND SYRUP SYSTEMS	3-2
ADJUST WATER FLOW RATE	3-2
ADJUST WATER-TO-SYRUP "RATIO"	3-2
ADJUST SIZE OF DRINK DISPENSED	3-2
CHAPTER IV <u>OPERATORS INSTRUCTIONS</u>	4-1
DAILY PRE-OPERATION CHECK	4-1
REPLENISHING CO2 SUPPLY	4-1
REPLENISHING SYRUP SUPPLY	4-1
COOLING UNIT MAINTENANCE	4-1
CHECKING WATER BATH	4-2
CHANGING WATER BATH	4-2
ADJUSTMENTS	4-2
ADJUSTING WATER FLOW RATE	4-2
ADJUSTING WATER-TO-SYRUP "RATIO" OF DISPENSED PRODUCT	4-2
ADJUSTING SIZE OF DRINK DISPENSED	4-2
TESTING FOR LEAKS	4-2
CHAPTER V <u>SERVICE AND MAINTENANCE</u>	5-1
PERIODIC INSPECTION AND CLEANING	5-1
TOPPER-II CABINET MAINTENANCE	5-2
CLEANING CONDENSER COIL	5-2
CHECKING/CHANGING WATER BATH	5-2
WATER PUMP MAINTENANCE	5-3
CARBONATOR MAINTENANCE	5-4
LUBRICATION	5-4
SERVICING CHECK VALVES	5-5
REPLENISHING CO2 SUPPLY	5-7

TABLE OF CONTENTS (cont'd)	PAGE
SYRUP FLAVOR CHANGE	5-7
CHANGING WATER FILTER CARTRIDGE (OPTIONAL).....	5-7
ADJUSTMENTS	5-7
HIGH-PRESSURE CO2 REGULATOR.....	5-7
LOW-PRESSURE CO2 REGULATOR.....	5-8
DIET SYRUP TANK CO2 REGULATOR.....	5-8
BRIX INSTRUCTION.....	5-9
CLEANING AND SANITIZING.....	5-11
 CHAPTER VI <u>TROUBLESHOOTING</u>	 6-1
COOLING UNIT	6-1
WATER PUMP MOTOR WILL NOT OPERATE	6-1
WATER PUMP MOTOR WILL NOT SHUT OFF	6-1
WATER PUMP WILL NOT SHUT OFF AND PRESSURE RELIEF ENGAGED.....	6-1
SHORT CYCLING OF WATER PUMP MOTOR.....	6-1
WATER PUMP CAPACITY TOO LOW	6-1
WATER PUMP OPERATES BUT WATER PUMP DOES NOT PUMP	6-2
FROZEN WATER BATH.....	6-2
COOLING OR CONDENSING UNIT NOT OPERATIONAL.....	6-2
AGITATOR MOTOR NOT OPERATING	6-2
COMPRESSOR DOES NOT OPERATE.....	6-2
COMPRESSOR WORKS CONTINUOUSLY BUT DOES NOT FORM SUFFICIENT ICE BANK	6-2
COMPRESSOR WILL NOT STOP AFTER SUFFICIENT ICE BANK IS PRODUCED	6-3
CONDENSER FAN MOTOR NOT OPERATING.....	6-3
DISPENSING VALVES.....	6-3
WATER OR SYRUP LEAKING FROM NOZZLE AFTER ACTUATION	6-3
NO WATER, NO SYRUP BEING DISPENSED FROM VALVE.....	6-4
NO SYRUP BEING DISPENSED.....	6-4
NO WATER BEING DISPENSED.....	6-4
DISPENSED PRODUCT CARBONATED TO LOW.....	6-4
DISPENSED PRODUCT MAKES FOAM AS IT LEAVES NOZZLE.....	6-4
DISPENSED PRODUCT COMES OUT CLEAR BUT FOAMS WHEN IT TOUCHES CUP OR GLASS.....	6-4
WATER-TO-SYRUP "RATIO" TOO LOW OR TOO HIGH	6-5
ADJUSTMENT OF SYRUP METERING PIN DOES NOT PRODUCE DESIRED WATER-TO-SYRUP "RATIO"	6-5
CARBONATION TROUBLESHOOTING FLOW CHART #1	6-6
CARBONATION TROUBLESHOOTING FLOW CHART #2.....	6-7
CARBONATION TROUBLESHOOTING FLOW CHART #3.....	6-8
NOTE SECTION.....	6-9

LIST OF FIGURES

Figure	Title	
1-1	EXPLODED VIEW OF TOPPER-II.....	1-3
1-2	ILLUSTRATED PARTS BREAKDOWN OF TOPPER-II.....	1-4
1-3	EXPLODED VIEW OF TOPPER-II-J.....	1-6
1-4	ILLUSTRATED PARTS BREAKDOWN OF TOPPER-II-J.....	1-7

TABLE OF CONTENTS (CONT'D)

Figure	Title	PAGE
1-5	ELECTRICAL SCHEMATIC 110V.....	1-9
1-6	ELECTRICAL SCHEMATIC S-1309 JUICE.....	1-10
1-7	ELECTRICAL SCHEMATIC 24V.....	1-11
2-1	SAMPLE OF A POSSIBLE INSTALLATION.....	2-2
2-2	HIGH-PRESSURE CO2 REGULATOR, (S-101)	2-3
2-3	LOW-PRESSURE CO2 REGULATOR, (S-121)	2-3
2-4	SUGGESTED WATER FLOW INSTALLATION.....	2-4
5-1	WATER PUMP, "Y" STRAINER & SCREEN	5-4
5-2	CHECK VALVES.....	5-5
5-3	COMPOSITE EXPLODED VIEW OF CHECK VALVES AND RELIEF VALVE	5-6

LIST OF TABLE

1-1	DESIGN DATA.....	1-1
2-1	LOOSE-SHIPED PARTS.....	2-1

PREFACE

INTERNATIONAL CARBONIC INC. has enjoyed over 53 years of manufacturing excellence in the field of carbonation and in the beverage related industry. We have had a long and proud history with quality as our standard and innovation as our goal. Originally started just after World War II in Canfield, Ohio as Carbonic Dispensers. We enjoyed patents on the first Sodajet type carbonator. This method of carbonation instantaneously carbonated the water to 100% saturation. We developed the first patented dispensing valve to dispense bulk beverage with carbonation equal to or in excess of bottled beverages. A valve with three flavors and soda was another first. We were the first to incorporate the total postmix package, i.e., carbonation, refrigeration, and the ability to dispense from one self contained unit. We have pioneered many such firsts and will continue to develop advanced systems for the future, such as electronic interrogatable portion controls to electronic liquid level controls.

We hope you enjoy this piece of equipment that has been produced to give many years of trouble free service. We thank you for your purchase and hope we may serve you in the future.

CHAPTER I

GENERAL DESCRIPTION

This chapter gives the description, theory of operation, and design data for the TOPPER-II, (T-II), TOPPER-II-J, (T-II-J) and related components.

SYSTEM DESCRIPTION

The TOPPER-II is a complete self contained remote cooling/carbonation unit which when combined with related components, will produce a variety of cooled carbonated and non-carbonated beverages.

The TOPPER-II consists of a condensing unit, a water reservoir, water-cooling coil, a carbonator tank, (carbonated systems only), an agitator pump, and optional syrup cooling coil(s) and dispensing valve(s).

For proper function the TOPPER-II must have a water supply, and electrical supply and drainage. The TOPPER-II is designed with a unique lift off drain pan that can be emptied at any convenient drain outlet. Other items that will be required if used in B.I.B., (Bag in Box), or transfer tank, (FIGAL), installations will be High-pressure regulator, Low-pressure regulator, connecting lines, quick couplers, or disconnects and CO₂.

WARNING: Before shipping or relocating a TOPPER-II into a freezing ambient environment empty plain and carbonated water. Syrup systems should be flushed, ice bank melted, and water drained from water bath. A freezing ambient environment will cause existing water in unit to freeze possibly resulting in damage to pump/motor assembly, syrup coils, water coil, water bath, valve(s), etc.

TABLE I - I

DESIGN DATA

COOLING UNIT

Overall cabinet dimensions:	TOPPER-II	TOPPER-II-J
Height	32 1/2"	32 1/2"
Width	15 3/4"	15 3/4"
Depth	21 1/2"	21 1/2"
Weights:		
Shipping	174 LBS.	145 LBS.
Dry weight	134 LBS.	111 LBS.
Operational Weight	222 LBS.	199 LBS.
Ice Bank	30 LBS.	30 LBS.
Capacities:	Unit water bath (no ice bank)	11 gallons
Refrigerant requirement (R-134-A)		184 grams
Ambient operating temperature		40 F to 100 F.

Electrical Requirements: The cooling unit requires a 115 VAC, single phase, 60 Hertz power circuit.

	T-II	T-II-J
Circuit Ampacity	12.9 Amps	6.7 Amps
Condensing Unit	5.4 Amps	5.4 Amps
Water Pump Motor	6.2 Amps	NA
Transformer	.5 Amps	.5 Amps
Agitator	.8 amps	.8 amps

Water Filter Recommended (Optional) See Manufacturer Specifications for Operating Conditions

Incoming Water Pressure Regulator (Optional)	Pressure 25 – 40
C02 High-pressure Regulator (Carbonated units only) PSI	70 – 75
C02 Low-pressure Regulator (Carbonated/Flavored units only)	BIB Approx. 40 PSI
C02 Low-pressure Regulator (Carbonated/Flavored units only)	FIGAL Approx. 30 PSI
C02 Low-pressure Regulator (Optional)	FIGAL Approx. 30 PSI
C02 Diet Drink Pressure Regulator (if required)	6 - 10 PSI
DISPENSING VALVES Ambient Operating Temperature	40 F to 100 F
Electrical Requirements: Operating Voltage	24VAC, 60hz

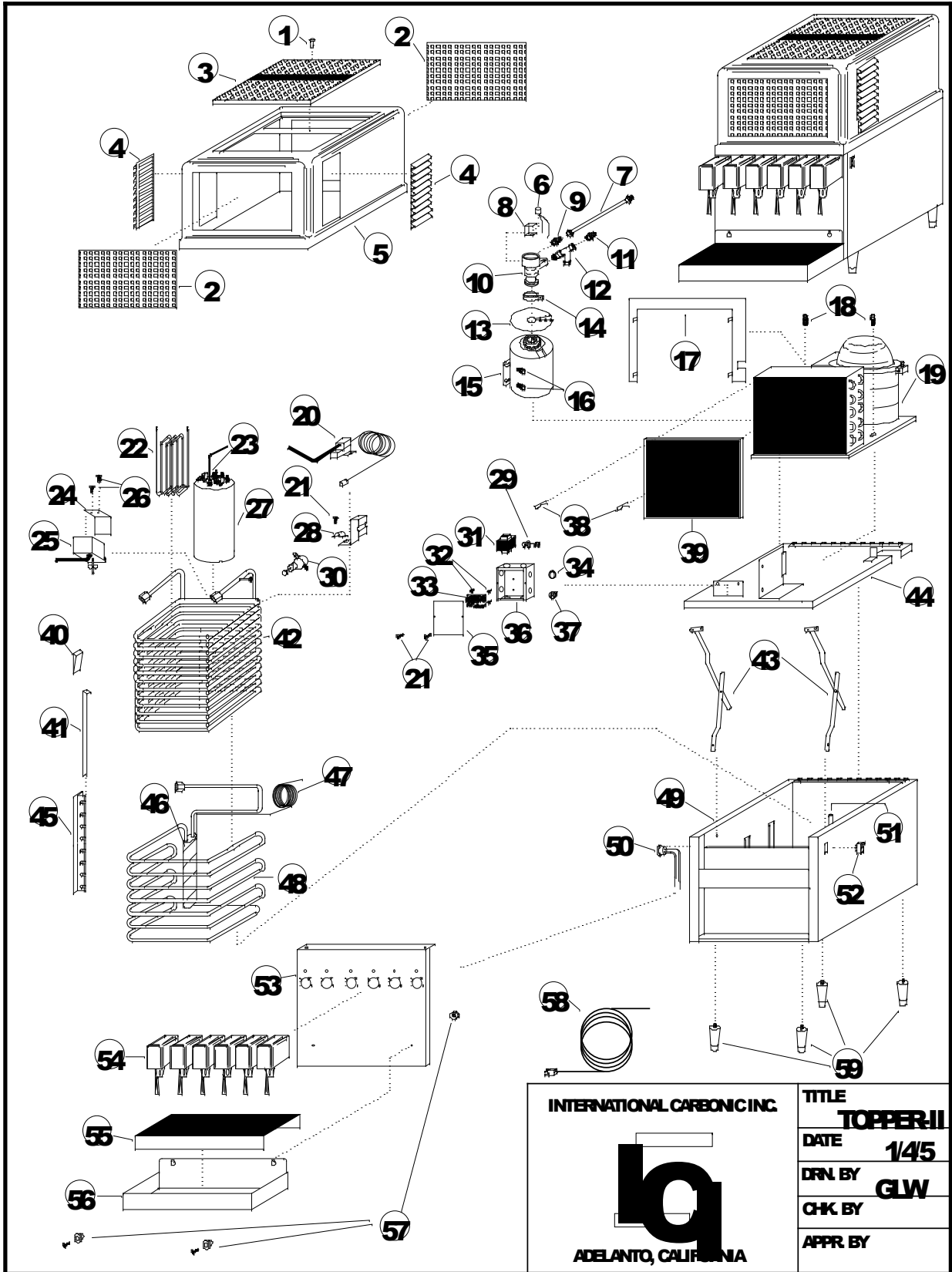



FIGURE 1-1
1-3

INTERNATIONAL CARBONIC INC.  ADELANTO, CALIFORNIA	TITLE	TOPPER II
	DATE	1/45
	DRN. BY	GLW
	CHK BY	
	APPR BY	

TOPPER-II

SYM	QTY	PART NO.	DESCRIPTION
1	1	S0777	NYLON FASTENER
2	2	S0725-V	FRONT AND REAR VENT
3	1	S0725-G	TOP GRID
4	2	S0725-L	SIDE LOUVER
5	1	S0724	COVER ONLY
		S0709	ITEMS 1,2,3,4, AND 5, (COMPLETE COVER)
6	1	S0103	PUMP PROTECTOR
7	1	S0723	WATER LINE, COPPER
8	1	S0104	PUMP PROTECTOR BRACKET
9	1	S0170	HALF UNION BRASS, 3/8 MF X 3/8 MP
10	1	S0200	PUMP, CARBONATOR
11	1	S0176	HALF UNION, BRASS, 3/8 M.P. X 1/4 M.F.
12	1	S0650	STRAINER, BRASS
13	1	S0199	MOTOR SHIELD
14	1	S0106	CLAMP, V BAND
15	1	S0096	MOTOR, CARBONATOR
16	2	A0045	5/16 X 18 FLANGE WHIZ LOCK SCREW, 1/2"
17	1	S0773	CONDENSER BAFFLE
18	2	A0046	5/16 X 18 FLANGE WHIZ LOCK SCREW, 3/4"
19	1	AEA3430YXAXA	CONDENSING UNIT, 1/4 H.P.
	1	AEA3430YXA	COMPRESSOR ONLY, 1/4 H.P.
20	1	S0513-A	ICE BANK CONTROL
21	5	A0020	8-32 X 3/8 T.H., S.S. SCREW
22	6	S0688	SYRUP COIL
23	1	S0072-40	SENSING PROBE ASSEMBLY
24	1	S1306-LG	AGITATOR PUMP BRACKET
25	1	S0835-L	AGITATOR PUMP
26	2	F0004	#8 X 1/2, SELF TAPPING, PH SCREW
27	1	S0265	CARBONATOR TANK ASSEMBLY
28	1	S1304-U	ICE BANK BULB BRACKET
29	1	E0664	STRAIN RELIEF

FIGURE 1-2
1-4

TOPPER-II Cont.

SYM	QTY	PART NO.	DESCRIPTION
30	1	S0208-A	WATER REGULATOR, OPTIONAL
31	1	E0276	TRANSFORMER, 40 VA
32	4	S1335	TERMINAL BOARD SPACER, NYLON, 3/8"
33	1	S0068-B	LIQUID LEVEL CONTROL, (LLC)
34	1	S7/8	HOLE PLUG
35	1	S1310	CONTROL BOX COVER
36	1	S1308	CONTROL BOX WITH COVER
37	5	S0046	BUSHING
38	2	S0704	CONDENSER FILTER HAIR PIN, COTTER
39	1	S0703	CONDENSER FILTER
40	4	S1323	EVAPORATOR GUIDE WEDGE
41	4	S0719	EVAPORATOR COIL RETAINER
42	1	S0694	WATER COIL, COPPER
43	1PR	S0681	SUPPORT HINGE
44	1	S0713	CONDENSER MOUNTING BASE
45	4	S0718	EVAPORATOR SUPPORT BRACKET
46	1	S0409-A	ACCUMULATOR
47	1	Z0010	CAP TUBE, 12' - .050
48	1	S0722	EVAPORATOR COIL ASSEMBLY
49	1	S0712	WRAPPER & BUCKET ASSEMBLY W/INSULATION
50	1	S1330	SWITCHLOCK W/KEYS
51	1	S0717	STANDPIPE
52	1	S0766	UNIT ON/OFF SWITCH
53	1	S0710	VALVE MOUNTING PLATE
54	6	PFC-II-QR	DISPENSING VALVES
55	1	S1157-A	CUP REST
56	1	S1157	DRAIN PAN W/CUP REST
57	1 SET	S0743	DRAIN PAN HARDWARE, SET
58	1	E0141-12	CORD
59	1	S0765	LEGS, 4", SET OF 4

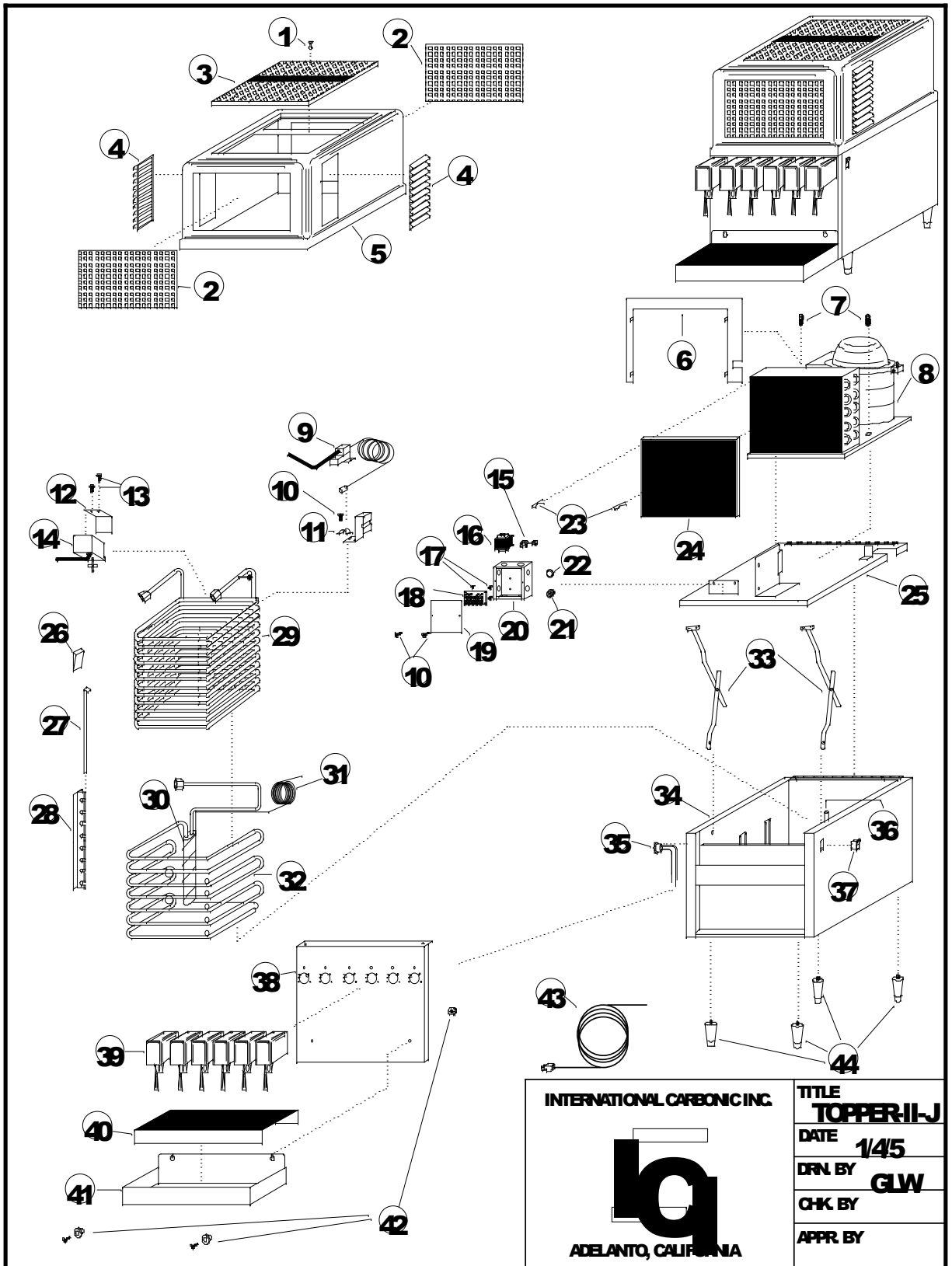

INTERNATIONAL CARBONIC INC.	TITLE TOPPER II-J
 ADELANTO, CALIFORNIA	DATE 1/45
	DRN BY GLW
	CHK BY
	APPR BY

FIGURE 1-3
1-6

TOPPER-II JUICE

SYM	QTY	PART NO.	DESCRIPTION
1	1	S0777	NYLON FASTENER
2	2	S0725-V	FRONT AND REAR VENT
3	1	S0725-G	TOP GRID
4	2	S0725-L	SIDE LOUVER
5	1	S0724	COVER ONLY
	1	S0709	ITEMS 1,2,3,4, AND 5, (COMPLETE COVER)
6	1	S0773	CONDENSER BAFFLE
7	2	A0046	5/16 X 18 FLANGE WHIZ LOCK SCREW, 3/4"
8	1	AEA3430YXAXA	CONDENSING UNIT, 1/4 H.P.
	1	AEA3430YXA	COMPRESSOR ONLY, 1/4 H.P.
9	1	S0513-A	ICE BANK CONTROL PROBE
10	5	A0020	8-32 X 3/8 T.H., S.S. SCREW
11	1	S1304-U	ICE BANK BULB BRACKET
12	1	S1306-LG	AGITATOR PUMP BRACKET
13	2	F0004	#8 X 1/2, SELF TAPPING, PH SCREW
14	1	S0835-L	AGITATOR PUMP
15	1	E0664	STRAIN RELIEF
16	1	E0276	TRANSFORMER, 40 VA
17	4	S1335	TERMINAL BOARD SPACER, NYLON, 3/8"
18	1	S1309	TERMINAL BOARD
19	1	S1310	CONTROL BOX COVER
20	1	S1308	CONTROL BOX WITH COVER
21	5	S0046	BUSHING
22	1	S-7/8	HOLE PLUG

FIGURE 1-4
1-7

TOPPER-II JUICE Cont.

SYM	QTY	PART NO.	DESCRIPTION
23	2	S0704	CONDENSER FILTER HAIR PIN, COTTER
24	1	S0703	CONDENSER FILTER
25	1	S0713	CONDENSER MOUNTING BASE
26	4	S1323	EVAPORATOR GUIDE WEDGE
27	4	S0719	EVAPORATOR COIL RETAINER
28	4	S0718	EVAPORATOR SUPPORT BRACKET
29	1	S0694-J	WATER COIL, COPPER
30	1	S0409-A	ACCUMULATOR
31	1	Z0010	CAP TUBE, 12' - .050
32	1	S0722	EVAPORATOR COIL ASSEMBLY
33	1PR	S0681	SUPPORT HINGE
34	1	S0712	WRAPPER & BUCKET ASSEMBLY W/INSULATION
35	1	S1330	SWITCHLOCK W/KEYS
36	1	S0717	STANDPIPE
37	1	S0766	UNIT ON/OFF SWITCH
38	1	S0710	VALVE MOUNTING PLATE
39	6	PFC-II-QR	DISPENSING VALVES
40	1	S1157-A	CUP REST
41	1	S1157	DRAIN PAN W/CUP REST
42	1 SET	S0743	DRAIN PAN HARDWARE, SET
43	1	E0141-12	CORD
44	1	S0765	LEGS, 4", SET OF 4

S-68-B

ELECTRICAL SCHEMATIC 120 VOLT

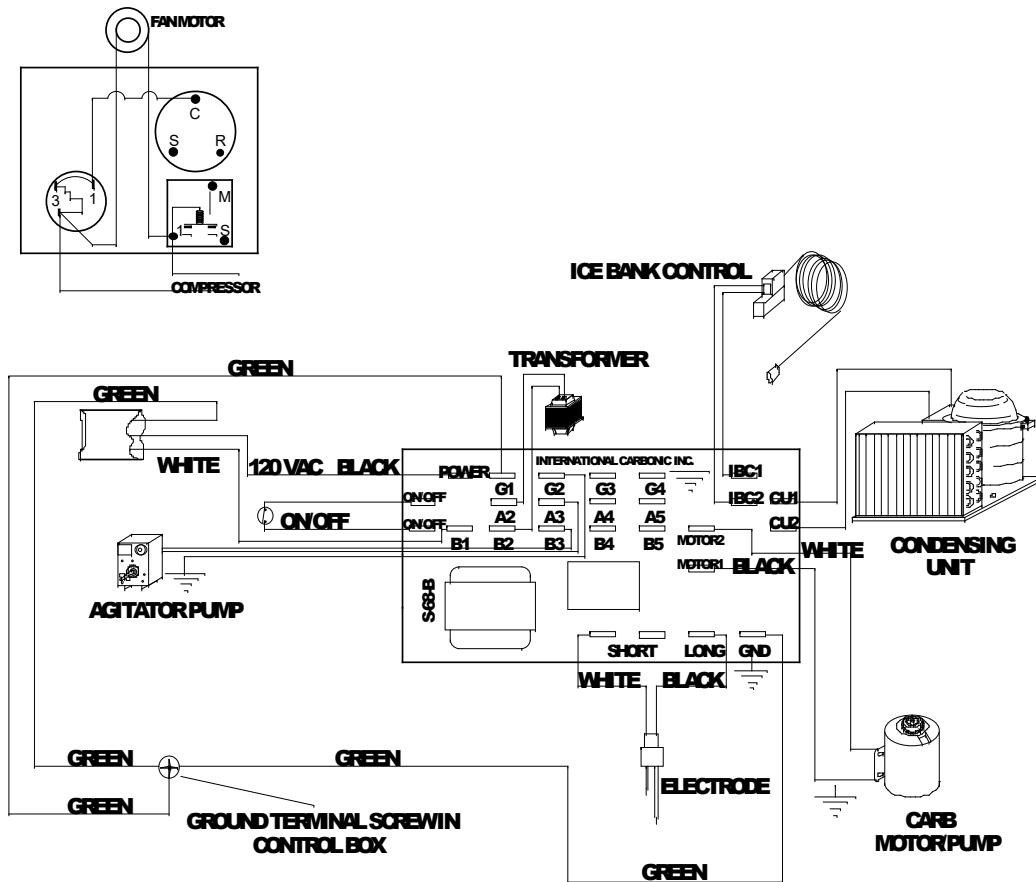

Note: Ground Terminals, Carbonator Tank
and Water Bath Must be
Commonly Grounded

NOTE: IF USING EXTRA 120V. ACCESSORIES SUCH AS RECIRCULATING MOTOR, ILLUMINATION ETC, MAKE CONNECTIONS AT TERMINAL A4, A5 FOR POWER/BLACK LEG. TERMINALS B4, B5, FOR NEUTRAL/WHITE LEG AND GROUND AT BOX OR ANY GROUND TERMINAL NOT IN USE. TERMINALS GROUND TERMINALS ARE G1, G2, G3, G4.

FIGURE 1-5
1-9

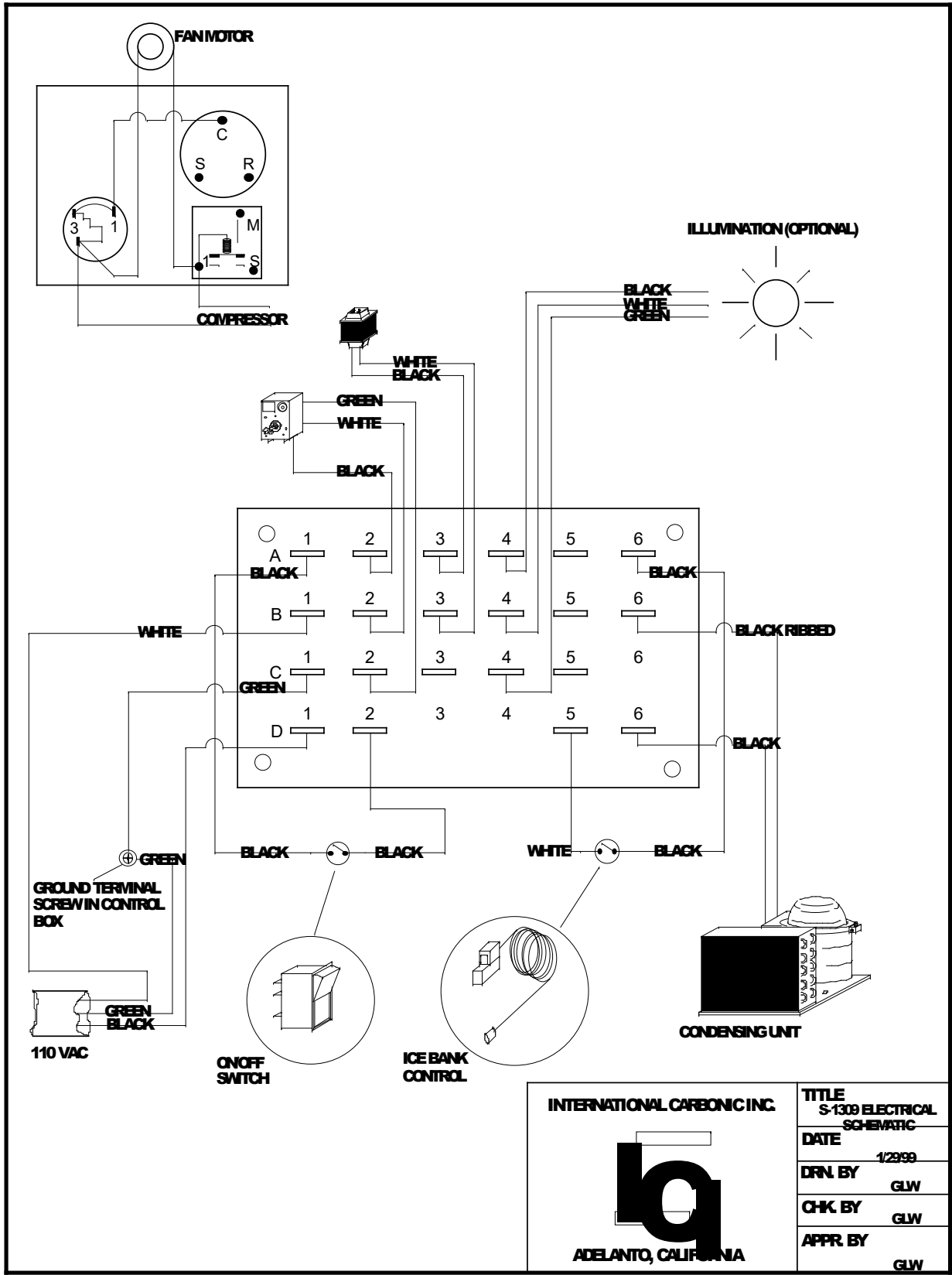
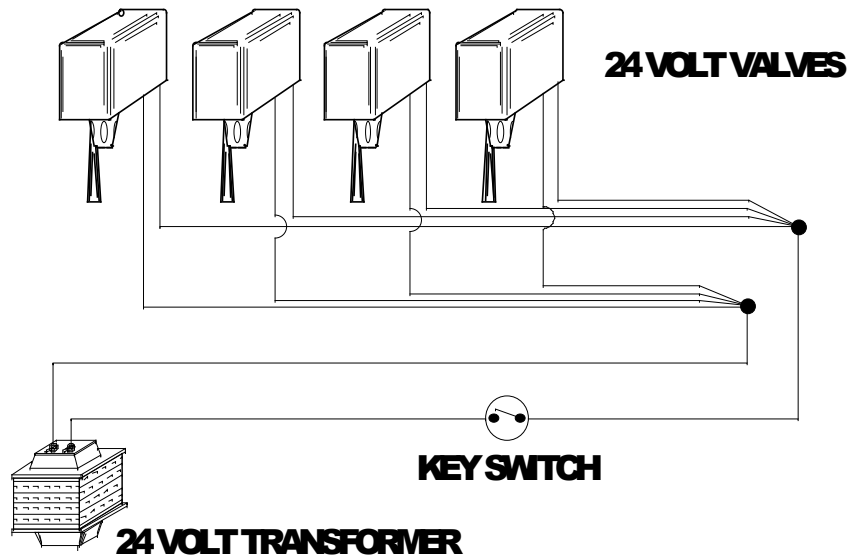
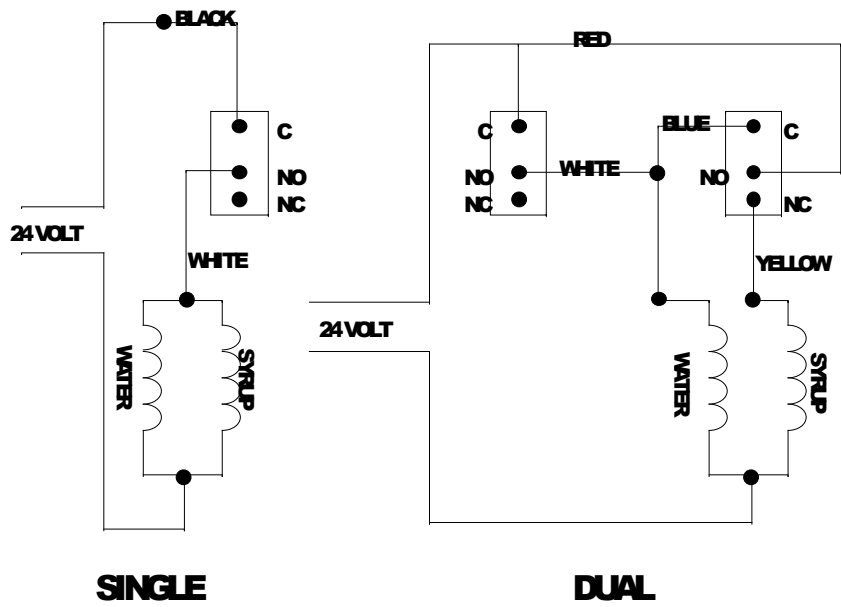

FIGURE 1-6
1-10

VALVE SCHEMATIC



ELECTRICAL SCHEMATIC 24 VOLT

FIGURE 1-7
1-11

THEORY OF OPERATION

The TOPPER-II was designed to manufacture and dispense carbonated or non-carbonated beverages much like your local bottling plant that cans or bottles your favorite carbonated or non-carbonated drink.

Initially water is chilled and then carbonated to dispense a quality drink. To chill the water the water is routed through a water coil that is submerged in an ice cold water bath. The temperature of the incoming water is at ambient temperature as it enters the water coil. As the incoming water passes through the water coil the heat is removed from the water in the water coil and chilled to a temperature acceptable for a quality drink. In both cases, carbonated or juice drinks, this procedure is performed. If the TOPPER-II is a carbonated unit the water is now routed into a carbonator tank where this cold water is mixed with CO₂. This water is now transformed into a carbonic acid, (soda water), and then routed to a valve where it will be mixed with a syrup concentrate and dispensed. In the case of the juice or non-carbonated drinks the carbonator tank is not needed so the chilled water is directed straight to the valve. Again it is mixed with a syrup concentrate and then dispensed.

The water bath holds approximately 11 gallons of water. A certain amount of this water will be transformed into ice, approximately 30 pounds. This water reserve and ice bank will act as a reservoir for refrigeration. This reserve is utilized during peak periods when the BTU output of the compressor is not sufficient to meet the demand of the draw.

It should be recognized that without refrigeration your carbonation system would not produce a drink that will hold carbonation. There is a direct relationship between dispensed temperature and the volumes of CO₂ that can be held in liquid form.

The following will give a general overview of the flow of individual circuits and a clearer understanding of our mini bottling plant.

Carbon dioxide gas (CO₂) passes from a CO₂ cylinder through high-pressure regulator (S-101). The high-pressure regulator regulates the CO₂ feeding the TOPPER-II and should be set at 70-75 PSI. The gas, after leaving the high-pressure regulator, is routed through flexible tubing to a low-pressure regulator. The flow of CO₂ is teed to go in two directions at the low-pressure regulator. One path takes the gas, set at 70 to 75 PSI, to the carbonator tank. This gas must be at a pressure greater than the incoming water by at least 25-PSI to assure the proper function of the carbonator. The second path of CO₂ is routed through low-pressure regulator to be regulated at pressures suitable for the syrup concentrate being dispensed. The low-pressure regulator may be set at many different settings but primarily the settings are directed towards B.I.B. or transfer tank type installations. The average settings may vary from 10 to 60 PSI, this of course will be influenced by length of run, ambient temperature and baume of product. Typically B.I.B. installations are set at an average of 40 PSI and transfer tank installations are set at an average of 30 PSI.

As discussed earlier plain water enters the TOPPER-II through the incoming water line. This water proceeds through the water coil where it is chilled prior to entering the carbonator tank or in the case of non-carbonated drinks chilled prior to going directly to a valve. Prior to entering the carbonator tank an optional regulator (S-208A) may be installed. This assembly is utilized to maintain water pressure feeding a non-carbonated valve when used in conjunction with a carbonated valve.

The water source should be regulated, this is normally performed by the use of an in line water regulator. If the water is not regulated and the water pressure is equal or greater than the incoming CO₂ the act of carbonation will be greatly inhibited or completely eliminated.

At the proper settings, the gas pressure will stop the water from entering the carbonator tank. To force the water into the tank a liquid level control and motor/pump will be used. This combination will force the water into the tank mixing the water and CO₂ together.

The carbonator utilizes a Soda Jet Recirculating Principle. Our Company pioneered this principle in the early 1950's. This principle produces instantaneous carbonation at extremely large capacities of 100 gallons per hour minimum.

The level of the carbonated water within the stainless steel mixing tank is used to operate the motor driven pump. The liquid level control, in conjunction with a probe housed in the carbonator tank, control the pump motor. The motor will come on when the carbonated water within the mixing tank recedes to a predetermined low level and stops the pump motor when the carbonated water reaches a predetermined high level.

During the cycle of operation, fresh water enters the carbonator through the soda jet after passing through a short tube to the water pump inlet fittings. The water pump has impellers which drives the water through a dual check valve and then through the soda jet and into the carbonator tank.

The position and angle of the soda jet is fixed to direct an extremely high velocity jet of fresh water so as to impinge upon the surface of the stored body of carbonator water within the stainless steel mixing tank. The force created by this jet of fresh water entering the mixing tank causes all the water within to cascade and foamesce through the carbon dioxide gas area in a continuous recirculating-manner.

This action causes a breakdown of the surface tension of the water, forming numerous minute gases filled water bubbles. The micro thin walls of these water bubbles surrounded by gas both inside and out, offer maximum water surface for the absorption of the gas. The size opening through this jet permits large volumes of water to be carbonated.

As the incoming water is being carbonated, the level within the tank rises to contact the upper probe, which will de-energize a relay on the liquid level control and stop the motor from turning the pump. This motor will be inactive until water within the tank recedes below the long probe, at which time, the relay on the liquid level control will close, engaging the motor once again.

CHAPTER II

INSTALLATION

This chapter covers unpacking and inspection, selecting location, installing TOPPER-II and related components, connecting water inlet and electrical requirements.

UNPACKING AND INSPECTION

Upon receiving unit, immediately remove unit from shipping carton and inspect for shipping damage.

NOTE: Before leaving the factory all TOPPER-II units were carefully inspected and the carrier has accepted and signed for them. Any damage or irregularities should be noted at the time of delivery and immediately reported to delivering carrier. Request a written inspection report from claims inspector to substantiate any necessary claim. File claim with delivering agency, not International Carbonic Inc.!

Unpack LOOSE-SHIPPED PARTS. At this time make sure all parts listed are present and in good condition. If any parts are missing, notify factory.

TABLE 2-1

LOOSE - SHIPPED PARTS

Item No.	Part No.	Name	Qty
1		Installation/Service Manual	1
2*	S-101	High-pressure CO2 Regulator	1
3*	S-221	Low-pressure CO2 Regulator	1
4	S-1157	Drain pan TOPPER-II	1
5	S-105	6' Gas Line (Inner Braid)	1
6	-----	Product Decals	1 per flavor
7*	S-208	Water Pressure Regulator	1
8*		Water filter	1
9*	S-208A	Water Pressure Regulator	1

* Optional

SELECTING LOCATION

IMPORTANT: Ambient temperature for TOPPER-II should not exceed 100 degrees "F". Operation of cooling unit in ambient above 100 degrees "F" can and will contribute to early failure of condensing unit and poor quality of finished product.

LOCATION RECOMMENDATIONS FOR TOPPER-II

1. Position unit as close as possible to proper electrical source, 120V 60HZ.
2. Position unit with a minimum of 2" space between bulkhead and cabinet for sufficient ventilation. Allow enough space between ceiling and unit for cover removal.
3. Position unit as close as possible to water source. Half inch gate valve recommended for water connection.
4. Enough space must be allowed to install C02 cylinder, syrup containers, racks, pumps, water filter, etc.
5. Position unit as close as possible to floor drain.

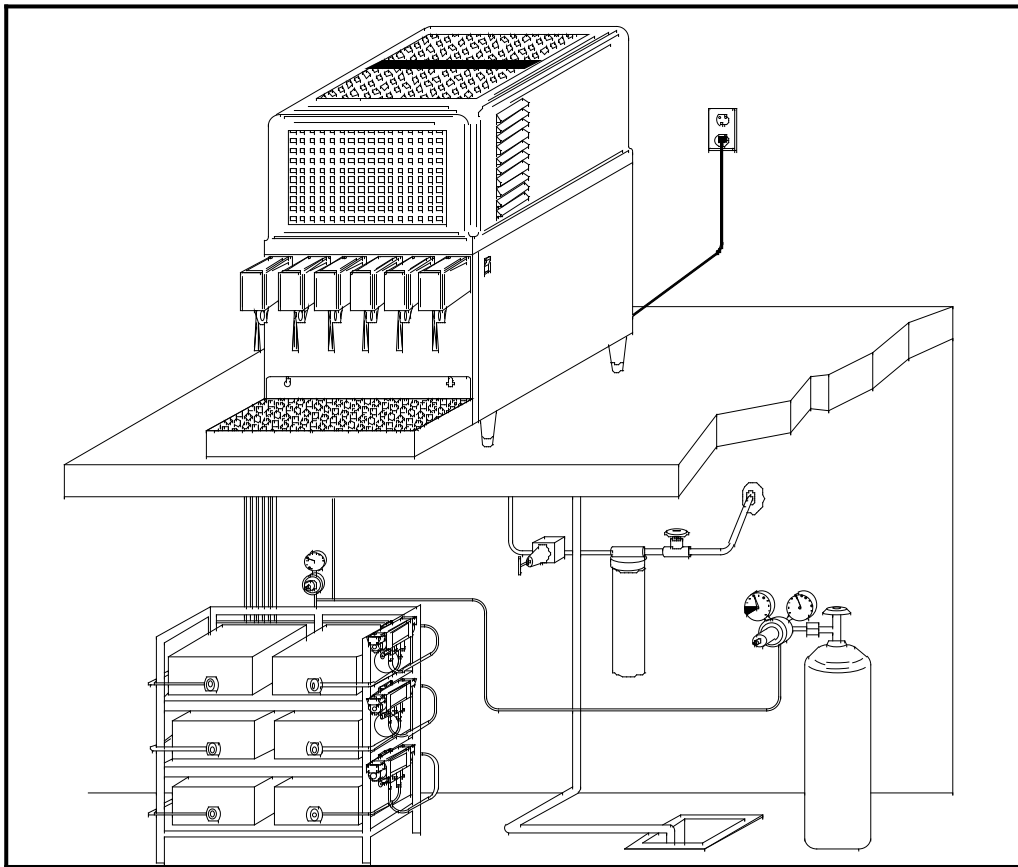

FIGURE 2-1. SAMPLE OF POSSIBLE INSTALLATION.

INSTALLATION

1. Make all connections: C02 gas, plain water and syrups.
2. Place TOPPER-II in position. Make sure sufficient space between bulkheads, walls and overhangs is available for proper air circulation around cooling unit.

INSTALL HIGH-PRESSURE C02 REGULATOR, C02 CYLINDER AND LINES
(FOR CARBONATED UNITS ONLY)

1. Install high-pressure C02 regulator, (S-101) on C02 cylinder using a new seal gasket.

MAKE SURE NEW WASHER IS INSIDE REGULATOR ASSEMBLIES COUPLING NUT BEFORE CONNECTING TO CYLINDER.

WARNING-: To avoid personal injury and/or property damage, always secure C02 cylinder with safety chain to prevent cylinder from falling. It is recommended that the C02 cylinder be installed away from heavily traveled areas such as doors, passageways, corridors, etc.

2. Connect 1/4" inner braided plastic tubing from outlet of high-pressure C02 regulator, (S-101), on C02 cylinder to Tee connection at low-pressure regulator, (S-221), using prefabricated gas charging line, (S-105).

3. A line must be fabricated at this time. Cut inner braid tubing to size and install nipple, (S-145), and nut, (S-150), to each end of tubing making sure either oetiker or ferrule is previously installed on line. Secure these connections by use of proper tool. Connect 1/4", inner braid plastic tubing from outlet of tee at low-pressure regulator, (S-221), (optional furnished with unit), to supplied line from unit marked gas.

INSTALL LOW-PRESSURE REGULATOR AND LINES (OPTIONAL)

1. Install low-pressure C02 regulator on the wall or another supporting structure in general vicinity of cooling unit, C02 cylinder, B.I.B. rack or syrup tanks.
2. Connect 1/4" inner braided plastic tubing from outlets of low-pressure C02 regulator, (S-221), to inlets of B.I.B. pump or syrup tanks.

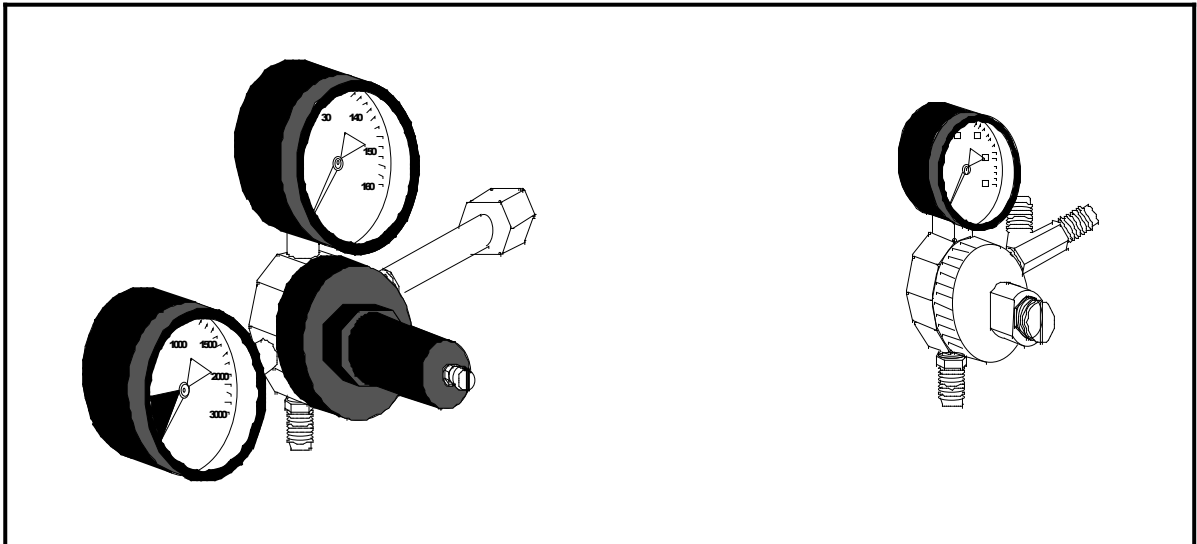

FIGURE 2-2
HIGH-PRESSURE C02 REGULATOR
REGULATOR
(S-101)

FIGURE 2-3
LOW-PRESSURE C02
REGULATOR
(S-221)

INSTALL WATER FILTER ASSY. (OPTIONAL)

1. Install water filter assembly on wall or other supporting structure.
2. Connect water filter assembly to inlet of valve on water supply line using minimum 3/8" I.D. water line.
3. Connect water filter assembly outlet to TOPPER-II plain water inlet fitting using minimum 3/8" I.D. water line. See CONNECTING WATER INLET.

When a water filter is used, it is important that it has a minimum 100 gallons per hour capacity and should be thoroughly flushed before it is connected to the water inlet connection.

INSTALL WATER PRESSURE REGULATOR (OPTIONAL)

If water pressure exceeds 40 psi, a water pressure regulator or water pressure reducing valve should be installed in the water supply line and adjusted to maintain a pressure of 25 to 40 psi, (The water regulator must have an orifice of at least 3/16" so as not to restrict the water flow through the valve. Valves that are built with 1/2" pipe thread connection usually have a sufficient orifice opening.)

INSTALL WATER HOLDING TANK (OPTIONAL)

When no water pressure is available or where the water supply system is inadequate, a water holding tank may be installed above the pump level. The pump will pump water from the holding tank to the carbonator.

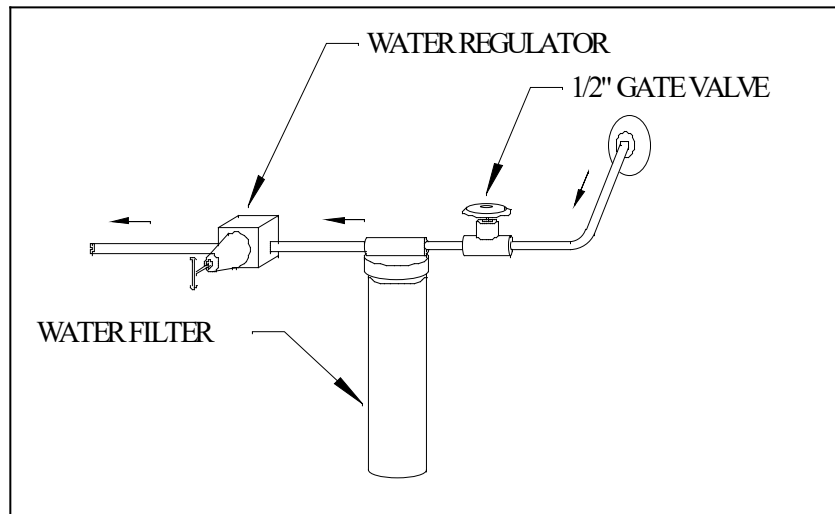

FIGURE 2-4. SUGGESTED WATER FLOW INSTALLATION

INSTALL DRAIN LINE

1. Connect drain line on TOPPER-II unit with drain using 3/8" I.D. clear plastic pipe or 3/8" copper tubing to nearest outlet.
2. Do not reduce drain connection from cabinet outlet.
3. Be sure all connections are water tight.

INSTALL B.I.B. OR SYRUP TANKS AND ACCESSORIES (OPTIONAL)

1. Place B.I.B. or syrup tanks as close as possible to TOPPER-II unit, preferably no farther than 5 feet.
2. Lay out syrup lines from unit to syrup pumps or tanks.
3. Connect lines from low-pressure regulator for B.I.B. or transfer tank installations.
4. Connect line from low-pressure regulator to Q.C.D. for B.I.B. or install quick disconnect for transfer tank type installations.
5. Install incoming syrup line to unit on Q.C.D. for B.I.B.
6. Install quick disconnect on incoming line to accommodate transfer tank installs.
7. Activate Q.C.D. or install quick disconnects to transfer tanks.
8. Check all connections for leaks, (see Chapter IV).

CONNECTING WATER INLET

WATER PIPE CONNECTIONS AND FIXTURES DIRECTLY CONNECTED TO POTABLE WATER SUPPLY SHALL BE SIZED, INSTALLED AND MAINTAINED ACCORDING TO FEDERAL, STATE, AND LOCAL LAWS.

The water connection on the TOPPER-II is made to a flexible water line by means of a 3/8", male flare. Due to the large capacity of the pump, any restriction of the incoming fresh water supply would starve the water pump and create noise within the pump, poor carbonation and extremely long running time.

After all primary water lines are made up, but prior to connecting water supply to cabinet, be sure to thoroughly flush all incoming water lines to remove all scale and any impurities that may be in the lines. It is important to remember that the TOPPER-II has a carbonator capacity of a minimum of 100 gallons per hour. Therefore, it is imperative that the fresh water conduit have not less than 3/8" I.D. passageway for any distance greater than ten feet from the TOPPER-II. It can be reduced to 3/8" O.D. copper tubing and connected to the water inlet connection within ten feet of the TOPPER-II. All water inlet connections are clearly tagged.

ELECTRICAL REQUIREMENTS:

The TOPPER-II requires a 120 VAC, single phase, 60 Hertz power circuit, and must be wired in accordance with N.E.C. or local ordinance.

NOTE: Check CHAPTER I for running amperage and connect to appropriate electrical circuit.

CHAPTER III

PREPARATION

All steps in previous chapters should be understood and carried out before proceeding.

PREPARING SYSTEM FOR OPERATION

Be sure that electrical power is unplugged, valve on CO₂ cylinder is closed, valve on water supply line is closed, and release pressure of CO₂ gas and water from carbonator tank.

PREPARING AND STARTING REFRIGERATION UNIT

1. TOPPER-II refrigeration is pre-set at factory and ready to operate.
2. Remove cover.
3. Fill water bath with clean water until water runs out of condensate drain outlet, (S-717).
4. Open water inlet supply line.
5. Plug TOPPER-II power cord into electrical receptacle box, turn power switch to the "ON" position. Make sure compressor, condenser fan motor, agitator motor start. The process of cooling the water bath will now commence. With ambient and water temperature of 75 degree "F" initial pull down or formation of complete ice bank will take approximately 4.5 - 5 hrs. When full ice bank has been formed, compressor and condenser fan motor will stop. Agitator will continue to operate, circulating water in water bath.

PURGE DISPENSING VALVES

Dispense water from dispensing valves until all air is purged from soda water and non-carbonated water lines.

ACTIVATE HIGH-PRESSURE CO₂ SYSTEM

1. Open valve on the CO₂ cylinder. Be sure to open valve completely or until valve is back seated.
2. Turn high-pressure CO₂ regulator screw clockwise until the pressure is 70 to 75 psi, Carbonated units only.

3. Dispense water from dispensing valves until the carbonator activates, carbonated units only.
4. Allow carbonator to run until it automatically shuts off. Pump is fully primed and carbonator is now ready for use, carbonated units only.
5. Check all connections on high-pressure CO₂ system for leaks. Repair any leaks that are found.

ACTIVATE LOW-PRESSURE CO₂ GAS AND SYRUP SYSTEMS (OPTIONAL)

1. Make sure high-pressure CO₂ regulator pressure is 70 to 75 psi.
2. Make sure all B.I.B. racks or syrup tanks are full.
3. Make sure all Q.C.D.,s are in a operational position or gas and syrup quick disconnects are connected tightly with syrup tanks.
4. Turn low-pressure CO₂ regulator screw clockwise until the pressure is approx. 40 psi for B.I.B. and approx. 30 psi for FIGAL.

NOTE: These pressures will vary depending on baume of product, type of pumps, etc.

5. If diet drink regulator is required turn CO₂ diet drink pressure regulator screw clockwise until the pressure is 6 to 10 psi.
6. Dispense syrup from dispensing valves until all air is purged from syrup lines and syrup is dispensed.
7. Check for syrup and gas leaks. Repair any leaks that may be found.

ADJUST WATER FLOW RATE

Adjust dispensing valves water flow rate as instructed in chapter IV, OPERATORS INSTRUCTIONS.

ADJUST WATER-TO-SYRUP "RATIO"

Adjust dispensing valves for Water-to-syrup "Ratio" of dispensed product as instructed in chapter IV, OPERATOR INSTRUCTIONS.

ADJUST SIZE OF DRINK DISPENSED (FOR PORTION CONTROL VALVES-PCT ONLY)

Adjust size of drink dispensed as instructed in chapter IV, OPERATOR INSTRUCTIONS.

CHAPTER IV

OPERATORS INSTRUCTIONS

This chapter covers operator's responsibilities for daily pre-operation check, adjustments, replenishing C02 and syrup supplies, cleaning, and sanitizing.

DAILY PRE-OPERATION CHECK

1. Make sure high-pressure C02 regulator's pound per square inch indicator is not in shaded portion of dial. If so, C02 cylinder is almost empty and must be replaced.

NOTE: This reading should be carried out at normal room temperature.

Make sure there is a sufficient syrup supply in all syrup containers. If not, replenish syrup supply.

REPLENISHING C02 SUPPLY

NOTE: If pound per square inch indicator of high-pressure C02 regulator on C02 cylinder is in shaded portion of the dial, C02 cylinder is almost empty and should be changed.

C02 supply must be checked daily and if necessary, replenished as instructed (see CHAPTER II).

REPLENISHING SYRUP SUPPLY

Syrup supply must be checked daily and if necessary, replenished as instructed (see CHAPTER II).

COOLING UNIT MAINTENANCE

NOTE: Air circulation through the condenser coil, required to cool the condenser coil/compressor, is drawn in through vents at the top and sides, through condenser coil and is exhausted out grills at the rear top and back of cover. Restricting air circulation through the cooling unit will decrease its cooling capacity.

To avoid needless and sometimes costly repairs, it is imperative to keep condenser fins clean. This may be accomplished by one of three methods. One method is use of a condenser brush (a longhaired, soft bristle brush) to gently sweep fins of condenser clean. Second method is to use a strong vacuum. The third method is to use C02 or an air hose to blow out condenser. The latter method should only be attempted after normal business hours to avoid dust contamination.

CHECKING WATER BATH

Periodically check water level in water bath. If it is low more water should be added as instructed for maximum product cooling. This dehydration will normally not occur in normal temperate climate zones. With normal humidity the opposite will occur therefore a condensate drain is installed. Any extra water in the water bath will exit the unit via the drain outlet. When unit is building it's first ice bank it is normal to have water overflow the into the drain hose.

CHANGING WATER BATH

Drain water bath a minimum of twice a year. This can be accomplished by siphoning water with short hose into bucket or removing over flow standpipe. Once water is drained and ice bank is melted, water bath, water coils, bath walls, tank, etc. should be cleaned. Fill water bath to the top of the standpipe, (S-717), with fresh water.

ADJUSTMENTS

Periodically C02 regulators should be checked for proper pressure settings and if necessary, adjust as instructed. These settings can be recorded in NOTE section of this manual.

ADJUSTING WATER FLOW RATE

If adjustment of water flow rate should be necessary, adjust as instructed.

ADJUSTING WATER-TO-SYRUP RATIO, "BRIX", OF DISPENSED PRODUCT

Water-To-Syrup BRIX" of dispensed product should be checked and if necessary, adjust as instructed.

ADJUSTING SIZE OF DRINK DISPENSED (FOR PORTION CONTROL VALVES-PCT ONLY)

Drink size of dispensed product should be checked and if necessary, adjust as instructed.

TESTING FOR LEAKS

1. Completely back off adjusting screw on low-pressure C02 regulator.
2. Close valve on top C02 cylinder.
3. Wait for 5 minutes or more. If pressure on high-pressure gauge decreases excessively, there is leak in the carbonator circuit.

4. All connections including cylinder valve should be coated with a soap solution. If bubbles appear a leak is apparent.

5. Always be sure that the low-pressure adjusting screw is completely backed off before testing carbonator circuit for leaks. Otherwise, gas going into syrup tanks would cause this high-pressure gauge needle to balance with pressure in syrup tanks, which would be a false indication of a leak in the carbonator circuit.

6. After it has been determined that there are no leaks in the carbonator circuit, open CO₂ cylinder valve and adjust low-pressure regulator to 15 psi. Allow enough time for the syrup tanks to fill completely with gas, (5 minutes or longer).

7. Next, completely back off low-pressure regulator adjusting screw, and if gauge needle of low-pressure regulator commence to move downward, there is leak in the low-pressure circuit. Check all connections with a soap solution, paying particular attention to syrup tank covers. If low-pressure gauge needle remains stationary, there is no leak.

CHAPTER V

SERVICE AND MAINTENANCE

This chapter describes service and maintenance procedures to be performed on TOPPER-II units and related components.

PERIODIC INSPECTION AND CLEANING

Daily:

1. Clean any syrup from storage tanks/B.I.B. racks, connecting sockets/Q.C.D.s and general syrup storage area with warm water.
2. Check the C02 gas supply. If cylinder pressure is below 500 P.S.I., replace the cylinder.

NOTE: Readings should be taken at normal room temperature, approximately 70 degrees "F" and above. If C02 cylinder is stored in a walk-in refrigerator, the P.S.I. indicator will read below 500 psi even when cylinder is full.

3. Check the C02 gas pressure supplying the carbonator and syrup tanks. These pressures should not change. If a change occurs repeatedly, contact your local service agency. It is suggested to make a comment about this occurrence in NOTE SECTION of manual.
4. Clean the beverage dispensing area.
5. Remove and clean nozzles and all exposed areas on valves.
6. Wipe exterior of unit with moist towel. Stainless cleans well with carbonated water.

Weekly:

1. Order syrup to maintain proper inventory.
2. Check all C02 gas connections for leaks.
3. Measure the water-to-syrup ratio on all beverages, adjust ratio if necessary.
4. Check condenser coil for obstructions or dirt.

Monthly:

1. Clean condenser fins or filter to make sure the refrigeration unit has adequate air-flow.
2. Inspect components of cooling unit water bath for cleanliness.
3. Check entire system for leaks or damaged components. Repair as necessary.

TOPPER-II CABINET MAINTENANCE

PERIODIC CLEANING

Periodically wash all external surfaces of TOPPER-II cabinet, rinse with clean water, then wipe dry with a clean soft cloth. DO NOT USE ABRASIVE TYPE CLEANERS.

CLEANING CONDENSER COIL

IMPORTANT: Air circulation through the condenser coil is required to cool the compressor. Air is drawn in through grills on the top of the cooling unit, through condenser coil and exhausted out grills on the top of unit. Restricting air circulation through the cooling unit will decrease its cooling capacity.

NOTE: Cleaning condenser coil should be done during non-use periods.

1. Unplug refrigeration unit power cord from electrical socket.
2. Remove cover of unit.
3. Vacuum or use a soft brush to clean fins of condenser coil. Use low-pressure compressed air or CO₂ gas to blow through condenser fins. This should only be performed after normal business hours to prevent dust contamination. A damp cloth on backside of condenser coil will prevent some dust contamination
4. Replace cover.
- S. Plug TOPPER-II power cord in electrical socket.

CHECKING / CHANGING WATER BATH

Periodically check water level in water bath. If it is low, more water should be added for maximum product cooling. Before adding more water, water bath and ice bank should be checked for excessive mineral deposit build up.

NOTE: The water in water bath should be changed and all components in water bath should be cleaned as often as necessary to keep it clean. A convenient time to perform this operation is when the system is being sanitized.

1. Unplug refrigeration unit power cord from electrical socket.
2. Remove cover from unit and hinge up refrigeration deck.
3. Look down into water bath (if necessary, use flashlight) and inspect water bath, ice bank and all components for cleanliness. Water, ice bank and all components should be clear and free of foreign particles. If ice bank is clear of foreign particles, it does not have to be melted down. Proceed to step 10, if foreign particles are present in the ice bank, proceed to step 4.
4. Siphon out water with short hose or pull out over flow standpipe.
5. Allow ice bank to melt. Hot water may be used to speed melting.

CAUTION: Never use an ice pick or other sharp instruments to remove ice from evaporator coil. Such practice can result in puncture to the refrigeration circuit.

6. Use fiber brush and carefully clean mineral deposit from all components.
7. Wash evaporator coil with a mild soap solution. Copper cleans well with mild solution of citric acid (1 cup of citric acid for 2 gallons of water). Stainless steel cleans well with carbonated water. Then rinse with clean water.
7. Rinse out water bath with clean water until water running out of siphon hose is clean.
9. Insert standpipe in drain hole
10. Fill water bath to top of standpipe.
11. Return refrigeration deck to flat position and replace cover.
12. Plug refrigeration unit power cord in electrical socket.

WATER PUMP MAINTENANCE

Warning: The water pump inlet strainer screen must be inspected and serviced at least once a year under normal circumstances or after any disruptions (plumbing work, earthquake, etc.), to the water supply systems that might cause clogged flow of water through system. Water pump with no screen or a defective screen in the strainer would allow foreign particles into water system and create a health hazard.

1. Unplug power cord from electrical socket.
2. Shut off plain water supply to water pump by closing shutoff valves in water supply line.
3. Shut off CO2 supply to TOPPER-II by closing shutoff valve on CO2 cylinder.
4. Remove cover from unit.
5. Lift up hinged condensing unit deck to gain access to water bath.
6. Pull up on carbonator tank relief valve to relieve CO2 pressure from tank.
7. Loosen screen retainer, then pull screen retainer and water strainer screen out of water pump port.
8. Clean any sediment from screen retainer and water pump port.
9. Inspect water strainer screen for holes, restrictions, corrosion, and other damage. **A water strainer screen should always be used, other wise particles could damage pump and foul the double check valve.**
10. Check "O" ring on screen retainer. Replace worn or damage "O" ring.

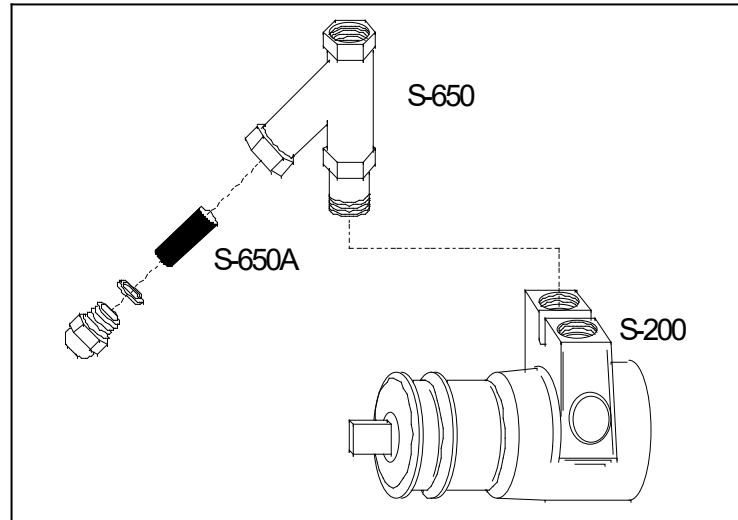

FIGURE 5-1
WATER PUMP, "Y" STRAINER & SCREEN

CARBONATOR MAINTENANCE

1. Unplug refrigeration unit power cord from electrical socket.
2. Remove cover, lift up hinged refrigeration deck to gain access to water bath.
3. Look down into water bath (if necessary, use flashlight) and inspect carbonator tank for leak. Air bubbles will arise from place of leak, if leak is below surface of water. If leak is above surface of water soap bubbles should be used to find any leak.
4. Shut off plain water supply to water pump by closing shutoff valve in water supply line.
5. Shut off CO₂ supply to refrigerating unit by closing shutoff valve on CO₂ cylinder.
6. Pull up on carbonator tank relief to relieve CO₂ pressure from tank.
7. Eliminate leak, tighten bad connections, or replace defective Probe assembly, water double check valve, (S-20), gas single check valve, (S-22), or valve relief, (S-215).
8. Service check valves as outlined in SERVICING CHECK VALVES.
9. Reassemble as necessary.
10. Return refrigeration deck to flat position and replace cover.
11. Plug refrigeration unit power cord in electrical socket.
12. Turn on plain water supply to water pump by opening shutoff valves in water supply line.
13. Turn on CO₂ supply to refrigerating unit by opening shutoff valve on CO₂ cylinder.
14. Activate all systems as outlines in CHAPTER III.

LUBRICATION

Water pump motors bearing must be oiled periodically. Refer to oiling instruction on motors. DO NO OVER OIL.

SERVICING CHECK VALVES

It is not recommended to disassemble the check valves unless it is absolutely necessary. As stated before this necessity would be prompted by earthquakes, disruption of water service, etc.

The symptoms of a malfunctioning check valve would be:

Water check valve	Carbonation through out water supply, i.e., basins, toilets, etc. or an activated vent valve.
Gas check valve	Water in C02 cylinder, water escaping from high pressure C02 regulator, (S-101), during cylinder change and possibly water in syrup containers. If any of the above symptoms occur proceed with the following:

1. Disconnect water line from double check valve outlet. Remove double check from water pump outlet fitting.
2. Remove one check valve from other, then disassemble each check valve as shown in Figure 5-2.
3. Wipe each part with clean lint-free cloth. Inspect each part, especially the ball, for burrs, nicks, corrosion, deterioration, and other damage. Discard ball "O"-ring, (S-13), and any damaged or suspicious parts and replace with new parts during re-assembly.
4. Reassemble each check valve as shown in Figure 5-2.

ALWAYS INSTALL NEW "O" RING, (S-13).

5. Assemble check valves together as shown in Figure 5-1.
6. Connect water inlet line to double check valve assembly.
7. Activate the system as outlined in CHAPTER III.

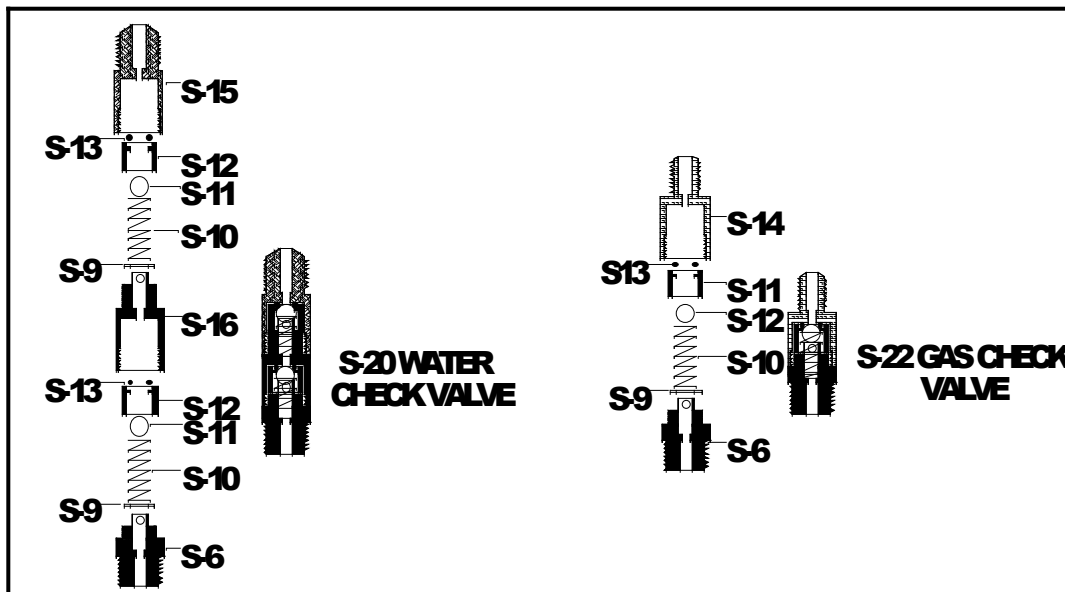
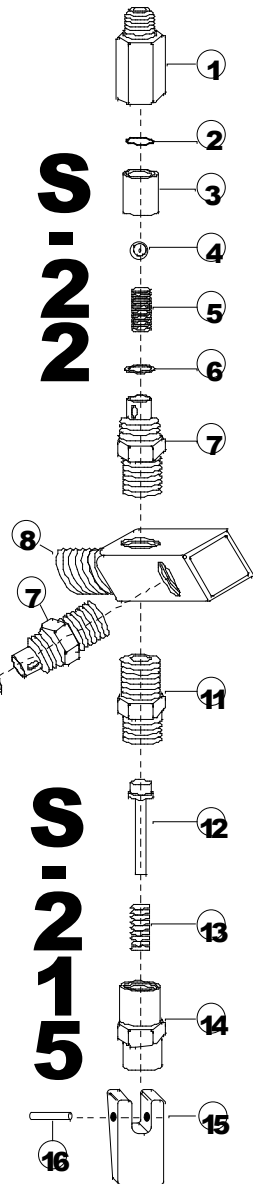

FIGURE 5-2 CHECK VALVES

SYM	QTY	PART NO.	DESCRIPTION
1	1	S-14	HOUSING, CHECK VALVE 1/4" M.F.
2	3	S-13	SEAT "O" RING CHECK VALVE
3	3	S-12	SLEEVE, SEAT RETAINER CHECK VALVE
4	3	S-11	BALL, CHECK VALVE
5	3	S-10	SPRING, CHECK VALVE
6	3	S-9	GASKET, CHECK VALVE
7	2	S-6 1/8	BODY, BASE, CHECK VALVE
8	1	S-29	OFF SET TEE
9	1	S-16	ADAPTOR HOUSING, DOUBLE CHECK VALVE
10	1	S-15	HOUSING, CHECK VALVE 3/8" M.F.
11	1	S	1/4" M.P.I., S.S. INLET
12	1	-	PLUNGER WITH SEAT
13	1	2	SPRING, 275 P.S.I.
14	1	1	SAFETY UPPER CAP
15	1	5	LEVER HANDLE
16	1	1	LEVER PIN
		8	LEVER PIN

S-229

S-222



S-20

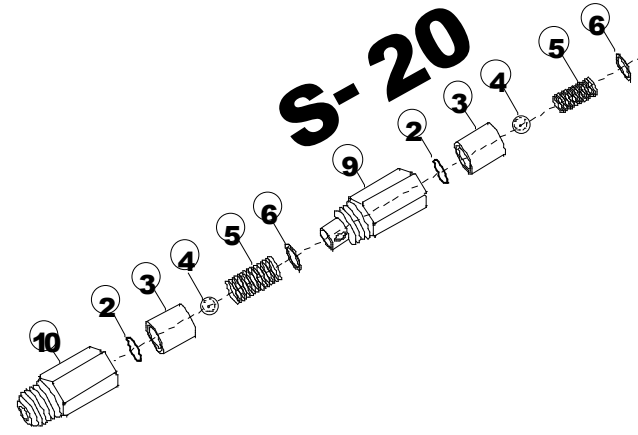

S-215

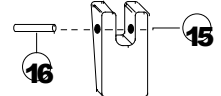

FIGURE 5-3. EXPLODED VIEW CHECK VALVES
5-6

REPLENISHING CO2 SUPPLY

1. Close empty CO2 cylinder shutoff valve.
2. Disconnect high-pressure CO2 regulator, then remove empty CO2 cylinder
3. Install full CO2 cylinder and connect high-pressure CO2 regulator. See installation procedure in CHAPTER II.

MAKE SURE CO2 CYLINDER IS POSITIONED IN UPRIGHT POSITION AND FASTENED WITH SAFETY CHAIN. ALWAYS OPEN CO2 VALVE COMPLETELY OR UNTIL BACK SEATED DURING OPERATION. WHEN BOTTLE IS EMPTY ALWAYS CLOSE VALVE ASSEMBLY COMPLETELY.

REPLENISHING SYRUP SUPPLY

1. Remove Q.C.D.s from empty B.I.B. or syrup & CO2 quick disconnects from empty syrup tank.
2. Install full syrup container in position, rinse Q.C.D.s or quick disconnects in warm water, then connect Q.C.D.s or syrup & CO2 quick disconnects to tank.
3. Activate valve until syrup flows from valve normally. See CHAPTER II.

SYRUP FLAVOR CHANGE

1. Remove Q.C.D.s from applicable B.I.B. or syrup quick disconnects from applicable syrup tank.
2. Sanitize applicable syrup system in accordance with instructions. See paragraph CLEANING AND SANITIZING in this chapter.
3. Install full syrup container in position, rinse Q.C.D.s or quick disconnects in warm water, then connect Q.C.D.s or syrup & CO2 quick disconnects to container.
4. Activate valve until syrup flows from valve normally. See CHAPTER II.

CHANGING WATER FILTER CARTRIDGE

Follow manufacturer's instructions for water filter.

ADJUSTMENTS

HIGH-PRESSURE CO2 REGULATOR

The high-pressure CO2 regulator will have two gauges that extend above and to the side of the bell housing screw area. The P.S.I. gauge will show graduated indications up to 3000 psi and be the gauge the farthest from the CO2 cylinder connection. This gauge will normally have a Red area indicating 500 psi to 0 psi. This gauge will be used to check volume of liquid in the CO2 cylinder. The other gauge will show regulated pressure that will be delivered to the TOPPER-II carbonation system. This gauge can be indicated from 0-160 psi up to 0-300 psi. By turning the high-pressure regulator adjustment screw clockwise we will increase pressure supplied to our carbonator which will be indicated on this gauge. To lower pressure to carbonation system it is recommended that the adjustment screw be turned counter clockwise several full turns and then the relief valve, (S-215), be lifted lowering pressure in carbonating system, now readjust. When adjusting CO2 high-pressure regulator a setting of 70-75 psi is recommended.

INLET CO2 PRESSURE TO CARBONATION SYSTEM SHOULD NOT EXCEED 75 PSI

LOW-PRESSURE CO2 REGULATOR

The low-pressure CO2 regulator setting can and will vary dramatically from one installation to the next. Variables such as distance from syrup containers to point of serving, horizontal or vertical runs, baume of product, to whether B.I.B. or transfer tanks are used will influence where the low-pressure regulator is adjusted.

A good starting point as an adjustment is:

40 psi for B.I.B.

and

30 psi for transfer tanks.

NOTE: After primary adjustment on low-pressure regulator always go to farthest serving station from syrup storage area and adjust heaviest baume syrup (normally ORANGE). If adjustment can be made proceed with all other flavors.

DIET SYRUP TANK CO2 REGULATOR S-121

The diet CO2 regulator is normally used only on transfer tank installations and should be set from 6 to 10 psi depending on length of run. In some cases where a vertical run is encountered pressure may be set as high as 15 psi. Excessive CO2 pressure may cause diet syrup to carbonate resulting in foam.

BRIX INSTRUCTIONS

1. Make sure carbonator/water flow is in an operating condition, i.e., high-pressure regulators set, water and power on and refrigeration in a ready to go mode. In the case of juice systems make sure water flow is un-restricted. It is also recommended that a water pressure regulator be utilized on all systems. Water bath systems must have an ice bank formed.
2. Adjust water flow to 6 ounces in 5 seconds.
3. Remove nozzle (twist and pull down), then insert syrup separator through nozzle, be it "S" type or plastic tube, and on $\frac{1}{4}$ " plastic syrup outlet located inside hidden nozzle area. Then press nozzle back in position.
4. Actuate valve until syrup separator is full of syrup. Hold brix cup close enough to valve outlet to form "S" on the flexible plastic tube so as to prevent any water following the flexible tube into syrup section. This formed "S" will also hold syrup in tube for a more reliable brix reading.
5. Actuate valve allowing the soda water to flow into large section of cup and syrup into smaller section. Adjust the syrup metering pin/flow-control as necessary to secure a proper brix. When proper brix syrup adjustments have been made, the two sections of the cup should fill to the desired ration.

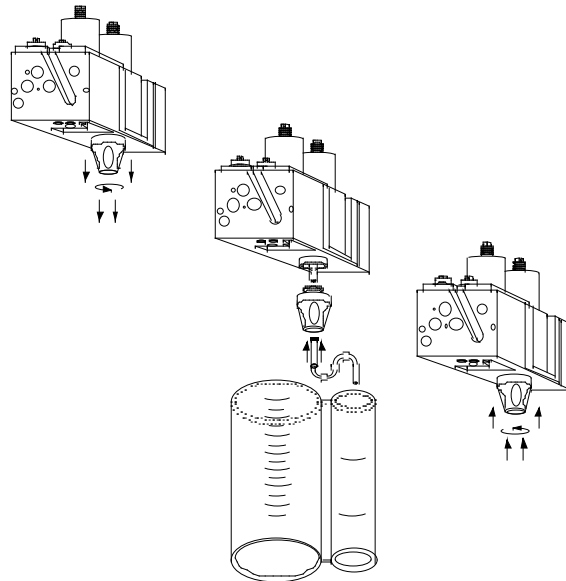

Brix Instructions Continued

BRIXING PFC-II VALVE

The water and syrup flows are individually adjusted by their respective metering pin or flow-controls. Located under the valve cover on the top rear of the valve, see illustration.

One recommended method utilizes the ratio brix cup. The brix cup is divided into two sections, one to hold up to 9 parts water and the smaller section to hold one or two parts of syrup. When adjusting a flavor with a ratio of more than 9 to 1 syrup 2 line must be used. When using syrup 2 line the waterside is doubled to 18 to 1 vs. 9 to 1.

When facing the valve, the syrup is always to the right and the water/soda is to the left. To decrease syrup or water flow, turn metering pin clockwise. To decrease syrup or water flow, when using flow control valves turn counter-clockwise. To increase, reverse rotation respectively. The ultimate goal is to achieve a proper ratio of water vs. syrup. This ratio can and will vary with differing products.

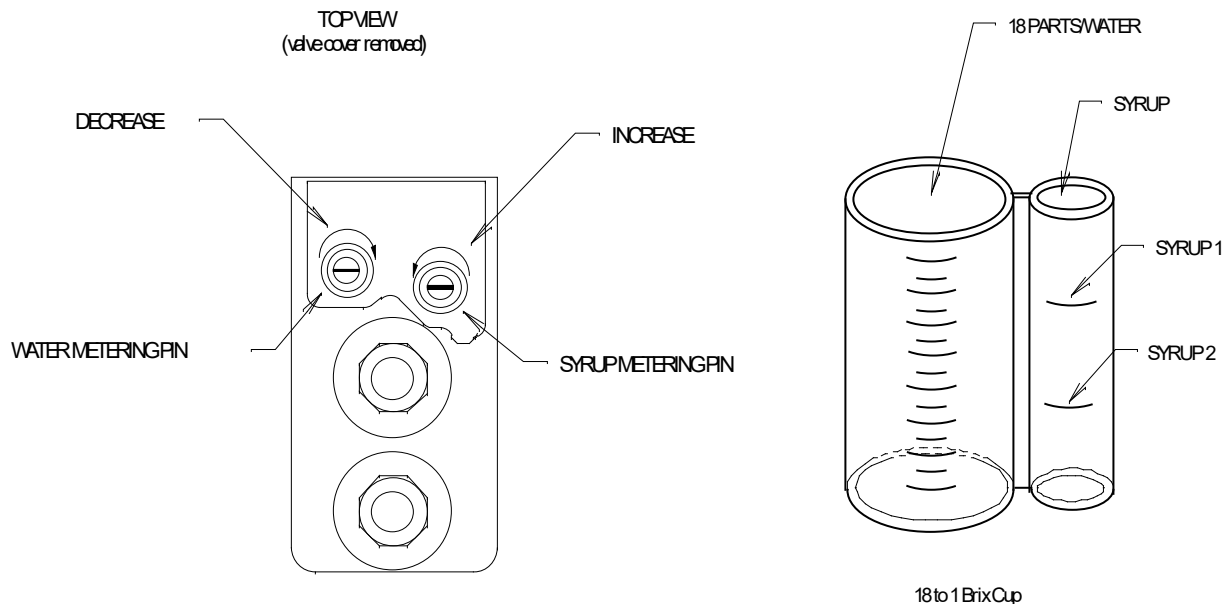

Maintenance:

Cleaning your valve is recommended to insure a constant quality drink. If a valve is not sanitized on a regular basis (nightly recommended), the possibility of foamy and off-tasting drinks is greatly increased.

1. Turn off key switch normally located on valve plate or side of cabinet. Or disconnect tower from electrical supply.
2. Clean all exposed areas of valve with mild soap or sanitizing solution and warm water.
3. Remove nozzle and place in warm water. Do not soak nozzle in bleach water, this will turn the nozzle yellow and cause deterioration. It is recommended to use a soft bristle brush, part No. S-1064, to clean any hard to get areas of valve or nozzle. Do not soak nozzle in extremely hot water, nozzle will warp.

SANITIZING PROCEDURES

Your local health department rules and general area cleanliness should determine the frequency at which the unit should be sanitized.

EQUIPMENT REQUIRED:

1. Stainless Steel containers (product tanks), or large volume container.
2. CO2 Supply If applicable (Same as used with dispensing unit).
3. Cleaning Agent.
4. Sanitizing Solution.
5. Phenolphthalein.

NOTE: One recommended cleaning agent and sanitizing agent is manufactured by:

MT. HOOD CHEMICAL CORP.
4444 N.W. Yeon Avenue
Portland, Oregon 97210

Trade names are: STAR - CHLORINATED CLEANER
CROWN - 12.5% SODIUM HYPOCHLORITE BLEACH

Use STAR at 18 oz. per 1 gallon of water yields 2% Sodium Hydroxide Solution.

Use Crown at 2 ounce per 9 gallons of water (gives 200 PPM of available chlorine) at a minimum contact time of 10 minutes.

1. Disconnect syrup containers and remove product from tubing by purging with carbon dioxide or flushing with warm water.
2. Visually inspect valve by removing nozzle and inspecting nozzle and valve cavity. Clean nozzle with cleaning agent, then sanitizing solution, then with potable water. Inspect valve cavity and if dirty clean with soft bristle brush. Clean exteriors of valve with a soft cloth and warm water. Replace valve nozzle then go to step #3.
3. Fill syrup lines with a caustic-based (low sudsing, non-perfumed, and rinsed) detergent solution, (STAR). The solution should be prepared in accordance with the manufacturers recommendations, but should be at least 2 percent sodium hydroxide. Make sure the syrup lines are completely filled and allow standing for at least 10 minutes.
4. Flush the detergent solution from the syrup lines with clean water. Continue rinsing until testing with phenolphthalein shows that the rinse water is free of residual detergent.
5. Fill the syrup lines with a low PH (7.0) chloride solution containing maximum 200-PPM chlorine. Make sure that lines are completely filled and allow standing for 30 minutes.
6. Reconnect syrup containers and ready Unit for operation.
7. Draw drinks to refill syrup lines and flush the chloride solution from the dispenser.
8. Taste the beverage to verify that there is no off taste.

NOTE: WHEN SANITIZING A TWO FLAVOR VALVE BOTH SYRUPS SHOULD BE FLUSHED SIMULTANEOUSLY, BOTH SYRUPS SHOULD BE CLEANED, (DETERGENT SOLUTION), SIMULTANEOUSLY, BOTH SYRUPS SHOULD BE FLUSHED UNTIL FREE OF DETERGENT SIMULTANEOUSLY AND BOTH SYRUPS SHOULD BE SANITIZED SIMULTANEOUSLY.

TROUBLE SHOOTING

IMPORTANT: Only qualified personnel should service the TOPPER-II unit and components.

WARNING: To avoid personal injury and or property damage, always disconnect electrical power, shut off plain water and CO2 supplies before starting any repairs. If repairs are to be made to the carbonated water system, bleed carbonated water system pressure before proceeding. If repairs are to be made to syrup system, remove quick disconnects from syrup tanks, or remove QCD from BIB, then bleed system pressure before proceeding.

CARBONATOR

Trouble		Probable Cause		Remedy
Water pump motor will not operate	1. 2. 3. 4. 5.	Inoperable water pump/ motor. Overheated motor (cut off by thermal overload protector). Electrode inside carbonator tank defective. L.L.C. assembly Inoperable. Loose electrical connection and/or open electrical circuit. Defective pump protector, S-103	1. 2. 3. 4. 5.	Replace water pump/ motor. Check for proper line voltage. Allow motor time to cool. Replace carbonator tank electrode. Replace L.L.C. assembly. Tighten connection and/or repair open circuit. Check line voltage. Replace pump protector
Water pump motor will not shut off	1. 2. 3. 4. 5.	Defective water pump. Electrode inside carbonator tank defective. L.L.C. assembly inoperable. Loose electrical connection and or open electrical circuit. Carbonated water leak.	1. 2. 3. 4. 5.	Replace water pump. Replace carbonator tank electrode. Replace L.L.C. assembly. Tighten connection and or repair open ground circuit. Find and repair leak.
Water Pump motor will not shut off and pressure relief engaged	1. 2.	Electrode inside carbonator does not sense ground. L.L.C. assembly inoperable.	1. 2.	Replace defective electrode or check and tighten ground connection at control box. Replace L.L.C. assembly.
Short cycling of water pump motor	1. 2. 3.	Ground connection loose or disconnected. Electrode inside carbonator tank defective. Carbonated water leak in system. L.L.C. assembly inoperable.	1. 2. 3.	Attach or tighten ground connection. Replace carbonator tank electrode. Repair carbonated water leak. Replace L.L.C. control assembly.
Water pump capacity to low	1. 2. 3. 4.	Inlet water volume supply to low. Water motor/pump worn out. Kinked or restricted water supply line. Foreign object in water pump or restriction to water pump.	1. 2. 3. 4.	Increase diameter of supply line, install holding tank. Replace water pump. Clear or replace restricted water supply line. Clear restrictions and check pump strainer for debris.
Water pump operates but water pump does not pump	1. 2. 3. 4.	Water supply to low or turned off. Inoperative water pump. Water supply filter clogged. Water pump strainer clogged.	1. 2. 3. 4.	Inlet water supply must be a minimum of 3/8". Replace water Pump. Replace filter. Clean water pump strainer.

Frozen water bath	<ol style="list-style-type: none"> 1. 2. 3. 4. 	<p>Bad ice bank control. Refrigerant leak causing undercharge. Defective agitator motor. Dirty water bath.</p>	<ol style="list-style-type: none"> 1. 2. 3. 4. 	<p>Replace bad ice bank control. Repair leak, evacuate and recharge. Replace defective agitator. Melt ice, empty & clean bath. Replenish w/fresh water.</p>
Cooling or condensing unit non-operational	<ol style="list-style-type: none"> 1. 2. 3. 4. 5. 6. 7. 8. 	<p>No electrical power. Defective ice bank control. Dirty condenser unit. Improper voltage/amperage Loss of refrigerant. Bad overload and relay. Compressor bad. Restriction (pinched or crimped line).</p>	<ol style="list-style-type: none"> 1. 2. 3. 4. 5. 6. 7. 8. 	<p>Plug power cord into electrical box. Check on/off switch. Replace ice bank control. Clean condenser unit w/vacuum cleaner. Check for proper Voltage/amperage. Repair leak and replenish refrigerant. Replace overload and relay Replace compressor. Repair, straighten or replace defective line.</p>
Agitator motor not operating	<ol style="list-style-type: none"> 1. 2. 3. 4. 	<p>Agitator propeller obstructed or lost. Low voltage. Loose, unplugged, or broken wiring. Bad agitator motor.</p>	<ol style="list-style-type: none"> 1. 2. 3. 4. 	<p>Remove obstruction or re-Attach propeller. Voltage must be at least 110 volt at terminals. Tighten connection or replace broken wiring. Replace agitator motor.</p>
Compressor does not operate	<ol style="list-style-type: none"> 1. 2. 3. 4. 5. 6. 7. 8. 	<p>No power source. Electrical power to cooling unit turned off. Low voltage. Loose, disconnected, or broken wire. Inoperative ice bank control. Inoperative overload protector or start relay. Inoperative compressor. Full ice bank.</p>	<ol style="list-style-type: none"> 1. 2. 3. 4. 5. 6. 7. 8. 	<p>Plug power cord to electrical box. Check line voltage. Turn on power switch to unit. Voltage must be at least 110 V at compressor terminals at start. Tighten connection or replace broken wiring. Replace ice bank control. Replace defective part. Replace compressor. Refrigeration not called for.</p>
Compressor works continuously but does not form sufficient ice bank	<ol style="list-style-type: none"> 1. 2. 3. 4. 	<p>Cooling capacity is exceeded by over drawing. Cooling unit located in excessively hot area. Air circulation through condenser coil is restricted Loss of refrigerant or in-sufficient charge.</p>	<ol style="list-style-type: none"> 1. 2. 3. 4. 	<p>Reduce amount of drinks taken per given time of install higher volume unit. Relocate cooling unit. Check and if necessary, clean condenser coil. Repair leak and/or recharge with sufficient refrigerant.</p>

Note: Ice bank freezes from bottom of evaporator upward. A refrigerant leak or insufficient charge might show ice at bottom and not at top of evaporator.				
Compressor will not stop after sufficient ice bank is produced	1. 2.	Ice bank control capillary tube kinked or broken. Ice bank control stuck in closed position.	1. 2.	Replace ice bank control. Replace ice bank control.
Note: During overload protector shut off condenser fan motor will continue to work. Otherwise, troubleshooting condenser fan motor problems is the same as "Compressor does not operate", paragraph in addition to the following.				
Condenser fan motor not operating	1. 2. 3.	Electrical cord loose or disconnected from condenser fan motor or compressor terminals. Fan blade obstructed. Inoperative condenser fan motor.	1. 2. 3.	Tighten connections or replace cord. Remove obstruction. Replace condenser fan motor.
DISPENSING VALVES				
Water or syrup leaking from nozzle after actuation	1.	Foreign debris under plunger seat or bent, creased stem.	1.	a. Disconnect syrup or water from affected valve. b. Relieve pressure by activating valve. c. Remove E-623 nut from syrup or water solenoid. d. Remove e-525 coil assembly from e-527 stem. e. Remove E-527 stem from valve body. Note: care should be taken not to dent smooth E-527 wall. f. Valve stem seat should be inspected for any foreign debris. If debris is found remove at this time, also check E-730 stem. Movement should be unrestricted and free. g. Inspect E-730 plunger seat for damage, replace if damaged. h. Reassemble by reversing above procedure.
No water, no syrup being dispensed from valve	1. 2. 3. 4. 5. 6.	No electrical power. Frozen water bath. Pinched or crimped lines. Broken sub-miniature switch. Bad transformer. Disconnected wire.	1. 2. 3. 4. 5. 6.	Plug power cord into electrical box. Check line voltage. See "Frozen water bath". Repair defective line. Replace defective switch. Replace defective transformer. Attach disconnected wire.

No syrup being dispensed	<ol style="list-style-type: none"> 1. 2. 3. 4. 5. 6. 7. 8. 	<p>Syrup container empty.</p> <p>Syrup lines crimped.</p> <p>CO2 cylinder empty.</p> <p>QCD of syrup installed incorrectly.</p> <p>Low-pressure regulator defective or plugged.</p> <p>Syrup disconnect not attached correctly.</p> <p>Loose electrical connection of syrup solenoid and or open electrical connection.</p> <p>Frozen water bath.</p>	<ol style="list-style-type: none"> 1. 2. 3. 4. 5. 6. 7. 8. 	<p>Replenish syrup supply.</p> <p>Straighten syrup lines.</p> <p>Change CO2 cylinder.</p> <p>Re-install QCD correctly.</p> <p>Repair or replace low-pressure regulator.</p> <p>Lubricate and attach.</p> <p>Tighten connection and/or repair open circuit. Check proper voltage.</p> <p>See "Frozen Water Bath".</p>
No water being dispensed	<ol style="list-style-type: none"> 1. 2. 3. 4. 5. 6. 7. 	<p>Plain water inlet supply shutoff closed.</p> <p>Water filter fouled/clogged.</p> <p>Pinched or crimped line.</p> <p>Loose electrical connection, 24 volt.</p> <p>Water pump motor worn out or damaged.</p> <p>Water pump worn out or damaged.</p> <p>Frozen water bath.</p>	<ol style="list-style-type: none"> 1. 2. 3. 4. 5. 6. 7. 	<p>Open plain water inlet supply line shut off valve.</p> <p>Replace filter or cartridge.</p> <p>Repair defective line.</p> <p>Tighten connection and or repair open circuit.</p> <p>Replace motor.</p> <p>Replace water pump.</p> <p>See "Frozen water bath".</p>
Volumes of CO2 to low in finished product	<ol style="list-style-type: none"> 1. 2. 3. 4. 	<p>High-pressure regulator out of adjustment.</p> <p>CO2 cylinder empty.</p> <p>Water, oil, or dirt in CO2 supply.</p> <p>Temperature above quality limits.</p>	<ol style="list-style-type: none"> 1. 2. 3. 4. 	<p>Adjust high-pressure regulator as instructed.</p> <p>Replace CO2 cylinder.</p> <p>Clean contaminated CO2 system, (lines, regulator, etc.) and sanitize as instructed.</p> <p>See refrigeration/machine specifications vs. volume requirements.</p>
Dispensed product makes foam as it leaves dispensing valve	<ol style="list-style-type: none"> 1. 2. 3. 4. 	<p>Pressure of CO2 to high.</p> <p>Syrup over-carbonated with CO2.</p> <p>Dirty nozzle and valve cavity.</p> <p>Temperature above quality limits.</p>	<ol style="list-style-type: none"> 1. 2. 3. 4. 	<p>Adjust high-pressure regulator as instructed.</p> <p>Remove syrup tank quick disconnects. Relieve pressure; shake tank vigorously, as necessary to remove over-carbonation.</p> <p>Clean contaminated nozzle and sanitize as instructed.</p> <p>See refrigeration/machine specifications vs volume requirements.</p>
Dispensed product comes out clear but foams in cup or class	<ol style="list-style-type: none"> 1. 2. 	<p>Oil film or soap scum in cup or glass.</p> <p>Ice used for finished drink is subcooled.</p>	<ol style="list-style-type: none"> 1. 2. 	<p>Use clean cups and glasses.</p> <p>Do not use ice directly from freezer. Allow ice to become "wet" before using. Note; crushed ice also causes foaming of beverage. Carbonation is released on sharp edges of the ice.</p>

Water-to-syrup ratio to low or too high	<ol style="list-style-type: none"> 1. 2. 3. 	<ol style="list-style-type: none"> 1. Syrup flow regulator not properly adjusted. 2. CO2 gas pressure in syrup tanks insufficient. 3. Syrup tubing I.D. insufficient. 	<ol style="list-style-type: none"> 1. 2. 3. 	<ol style="list-style-type: none"> 1. Adjust water-to-syrup ratio (see dispensing station installation instructions). 2. Adjust low-pressure regulator as instructed. 3. Increase syrup tubing I.D. Note: see "Brix instructions"
Adjustment of syrup metering pin does not produce desired water-to-syrup ratio	<ol style="list-style-type: none"> 1. 2. 3. 4. 5. 6. 	<ol style="list-style-type: none"> 1. No syrup supply. 2. Syrup tank quick disconnects not secure. 3. Low-pressure CO2 regulator out of adjustment. 4. B.I.B. QCD disconnected or improperly installed. 5. Syrup line restricted. 6. Dirty or inoperative metering pin or piston in syrup flow control. 	<ol style="list-style-type: none"> 1. 2. 3. 4. 5. 6. 	<ol style="list-style-type: none"> 1. Replenish syrup supply as instructed. 2. Secure quick disconnects. 3. Adjust low-pressure CO2 regulator as instructed. 4. Connect B.I.B. disconnect securely. 5. Clear restriction or replace restricted line. 6. Disassemble and clean syrup flow control. Adjust water-to-syrup ratio, see "Brix instruction".

CARBONATION TROUBLE SHOOTING FLOWCHART #1

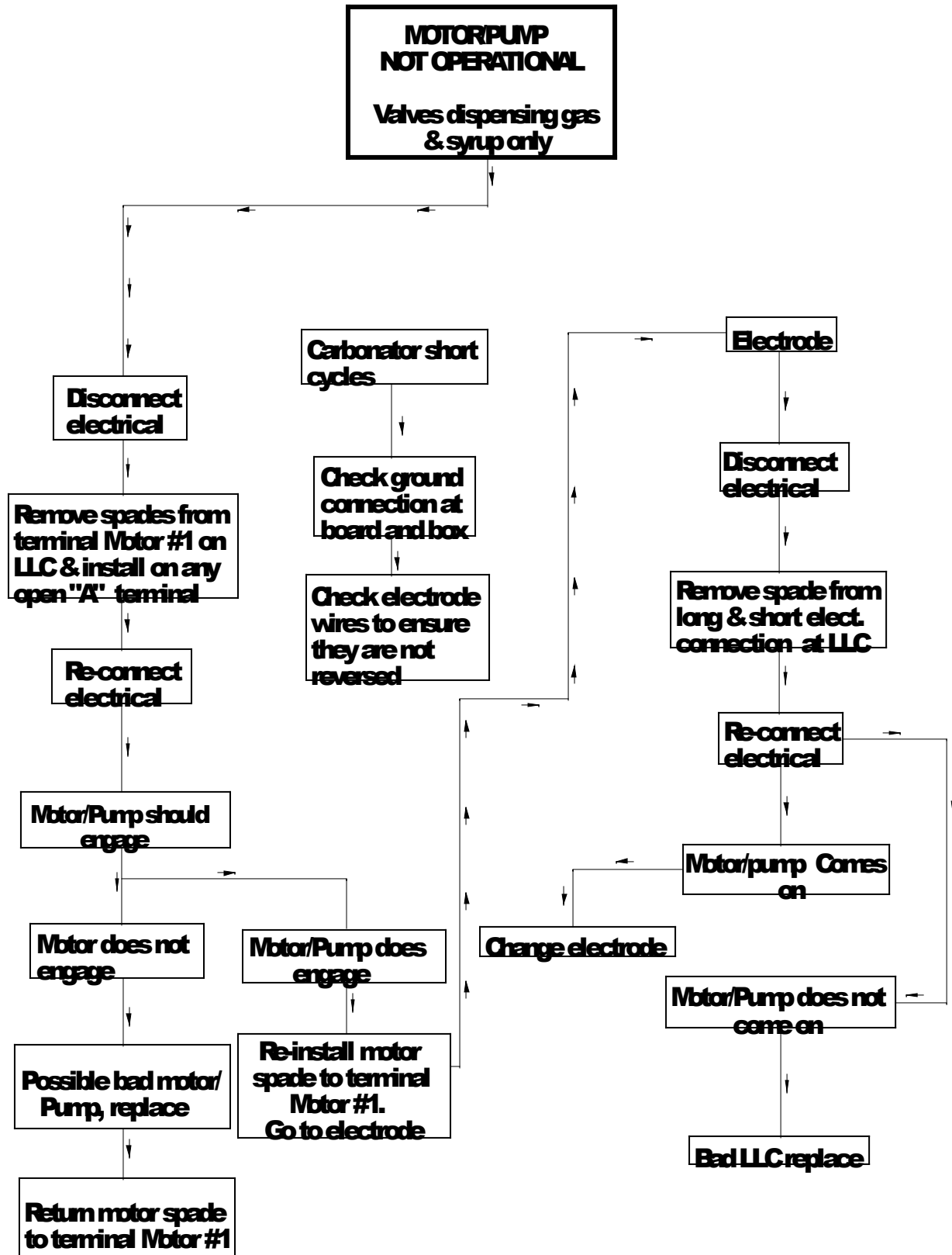

CARBONATION TROUBLE SHOOTING FLOWCHART #2

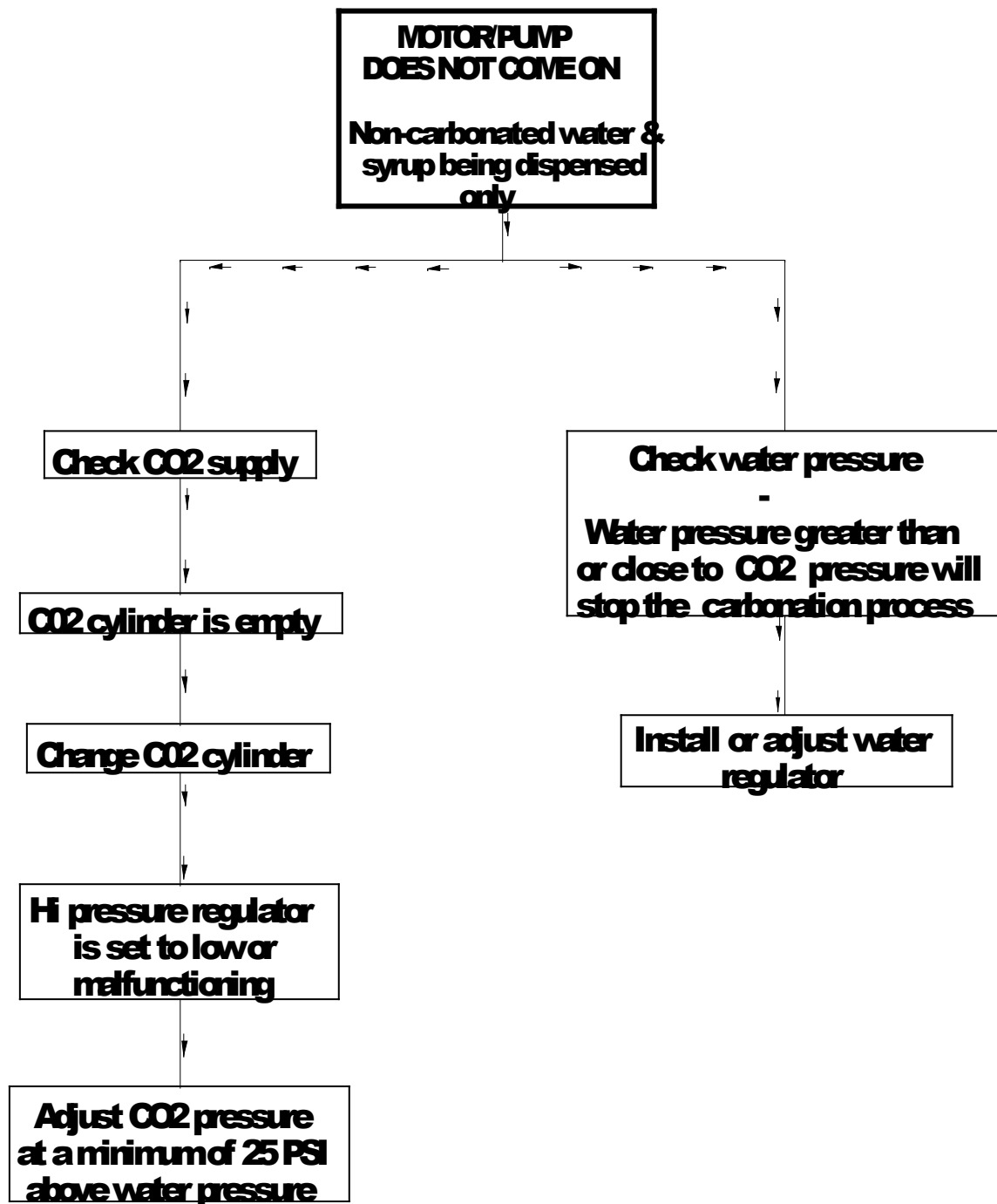

CARBONATION TROUBLE SHOOTING FLOWCHART #3

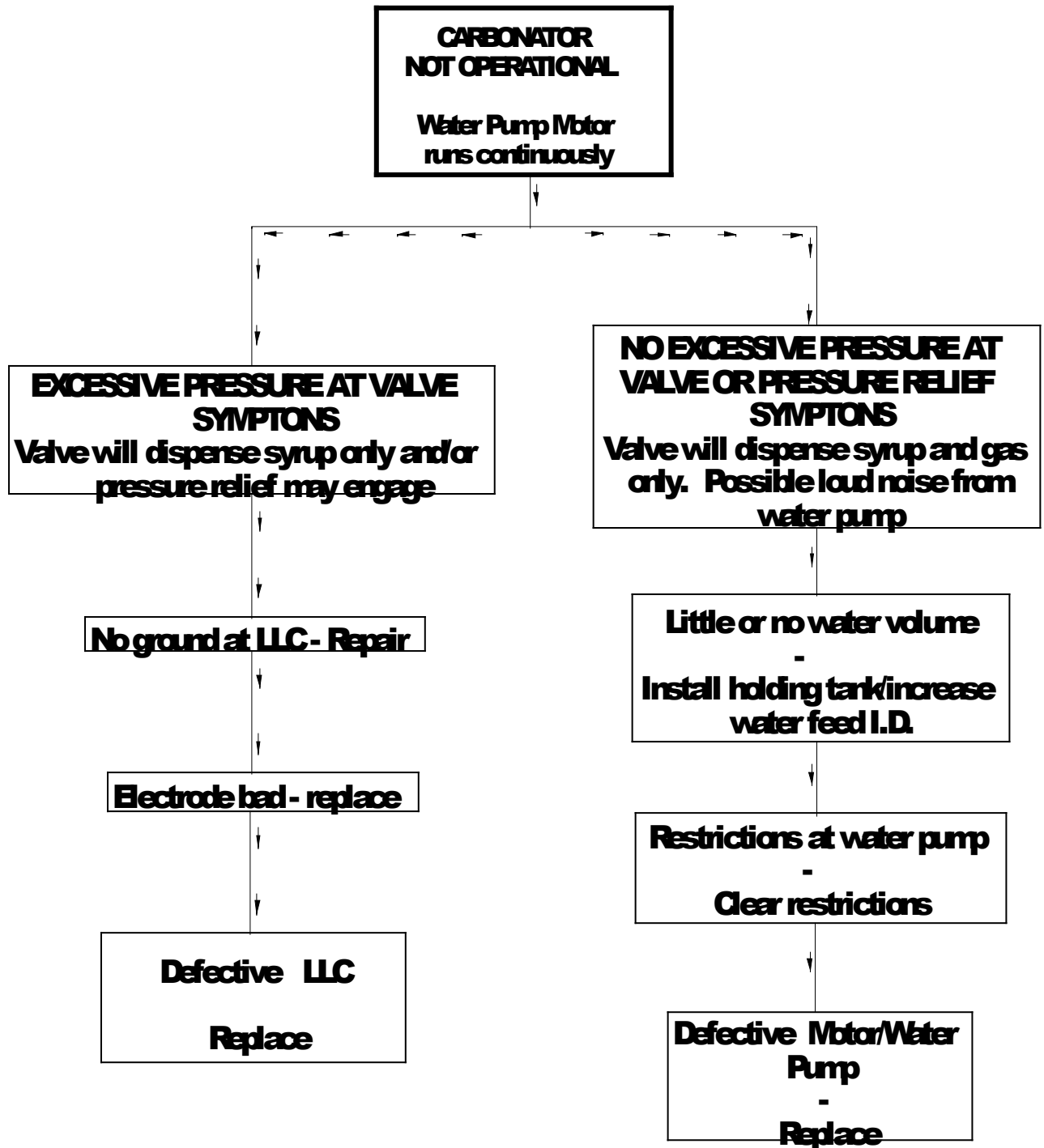

NOTE SECTION

Frequently Called Numbers:

_____	_____
_____	_____
_____	_____
_____	_____
_____	_____
_____	_____

CO2 SETTINGS:

High Pressure		PSI
Low Pressure		PSI

Product Setup:

#1		#2
_____	_____	_____
_____	_____	_____
_____	_____	_____
_____	_____	_____
_____	_____	_____
_____	_____	_____
_____	_____	_____
_____	_____	_____
_____	_____	_____
_____	_____	_____
_____	_____	_____
_____	_____	_____
_____	_____	_____
_____	_____	_____
_____	_____	_____
_____	_____	_____
_____	_____	_____
_____	_____	_____
_____	_____	_____